



Chazelles

CHEMINÉES - INSERTS - POÊLES



CATALOGUE GÉNÉRAL



Passez en mode bien-être

Faites le choix du confort et de la sécurité d'une grande marque française. Depuis plus de trente ans, Chazelles investit sur une politique «haute performance». Nous accordons un grand soin à la qualité des matériaux sélectionnés dans la fabrication de nos produits afin de garantir les meilleurs rendements énergétiques.

EMBRACE THE 'WELLNESS' LIFESTYLE

Choose the security and the reliability of a well known French brand. For over 30 years, Chazelles constantly follows a "high performance" policy. We take the greatest care of the quality of the materials selected for the manufacturing of our products, to ensure the best energy efficiencies.



Chazelles est la Première marque française à proposer à ses clients la Garantie bien-être 10 ans*.

Chazelles is the first French brand to offer its customers 10 YEARS WARRANTY.*

Depuis plus de trente ans, Chazelles conçoit, développe dans son usine les cheminées, poêles et inserts de votre habitat.

For over thirty years, in its factory, Chazelles designs, develops fireplaces, stoves and inserts for your home.

Chazelles

Usine : Route de Marthon
16380 Chazelles - FRANCE
www.chazelles.com

* Renseignez-vous auprès de votre revendeur Chazelles.
Information form your dealer

SOMMAIRE

CONTENT

CHAZELLES

- 2 Fabricant français - French manufacturer
- 4 Le chauffage Haute Performance - High Performance heating
- 6 La garantie Bien-être 10 ans - 10 years wellness warranty
- 8 Réseau de distribution - Dealer's network
- 10 La qualité - Quality
- 12 Le Sur-Mesure - Custom-made

CHEMINÉES

FIREPLACE :

- 16 Contemporaines - Contemporary
- 42 Antiquaires - Antic
- 48 Classiques - Classic
- 52 Rustiques - Rustic
- 56 Essentielles - Essential

INSERTS

INSERTS :

- 62 Granulés Pellet
- 70 Bois wood burning
- 86 Bois ventilé ventilated wood burning
- 88 Sur-mesure custom made
- 92 Hydro Hydro
- 98 Gaz Gas

POÊLES

STOVES :

- 106 Granulés Pellet
- 120 Bois Wood
- 148 Gaz Gas

CHAZELLES AU NATUREL

NATURAL BRAND:

- 152 Repères & Labels - Reference & certification
- 154 Matériaux - Materials
- 158 Côté jardin - Garden living
- 162 Informations techniques - Technical Information
- 168 Index - Index
- 169 Symboles - Symbols

flashcode



web



Dans le cadre du label Ecodesign, et en raison de la saturation des laboratoires, certains produits sont encore en cours de tests avant la sortie du catalogue. Pour plus d'informations, et pour consulter la validation des produits, merci de vous rendre sur notre site internet : www.chazelles.com.



Chazelles

FABRICANT FRANÇAIS

FRENCH MANUFACTURER

La tradition, le savoir-faire et l'innovation technologique au service d'une très haute maîtrise du feu.

Depuis plus de quarante ans, Chazelles conçoit et fabrique dans son usine les cheminées, poêles et inserts de votre habitat.

Mais a aussi sélectionné dans son catalogue, les meilleures marques européennes pour vous proposer un choix optimal.

Tradition, know-how and technological innovation at the service of a very high mastery of fire.

For more than forty years, Chazelles has been designing and manufacturing fireplaces, stoves and inserts in its factory.

But has also selected in its catalogue the best European brands to offer you an optimal choice.



LE CHAUFFAGE HAUTE PERFORMANCE

HIGH PERFORMANCE HEATING



Chazelles

LA MAÎTRISE TECHNOLOGIQUE DU FEU

TECHNOLOGICAL MASTERY OF FIRE

La sérénité Chazelles, c'est l'assurance d'un matériel haute performance, vous offrant les meilleures garanties de chauffage et de fiabilité dans le temps. Nous maîtrisons l'ensemble de la chaîne : de la conception à la fabrication.

Chazelles relies on its high-performance appliances, giving you the best guarantees heating and reliability over time. We control the entire line : from design to manufacturing.



GARANTIE JUSQU'À

10 ANS

Chazelles

VOTRE MEILLEURE
GARANTIE
BIEN-ÊTRE

THE BEST GUARANTEE OF WELLNESS

Parce que la sérénité Chazelles, c'est aussi la fiabilité maximale d'un matériel Haute Performance. Chazelles est la Première marque française à proposer à ses clients la GARANTIE BIEN-ETRE 10 ANS*.

Chazelles serenity, it is also the maximum reliability of equipment High Performance. Chazelles is the first French brand to offer its customers 10 YEARS WELLNESS WARRANTY.*



*Renseignez-vous auprès de votre revendeur Chazelles.
Information from your dealer.

SIÈGE SOCIAL
À CHAZELLES
EN CHARENTE

POITOU
CHARENTES

LIMOUSIN

AUVERGNE



Chazelles

EN FRANCE, ET DANS LE MONDE

IN FRANCE AND WORLDWIDE

EN FRANCE...

Le réseau de Chazelles compte plus de 110 professionnels répartis sur tout le territoire national.

Votre concessionnaire Chazelles n'est pas qu'un simple vendeur ; professionnel aguerri il saura vous faire profiter de son expertise, et vous faire bénéficier du service Chazelles :

- Pour vous guider dans le choix de votre cheminée ou de votre appareil de chauffage, en fonction de vos attentes en matière : de décoration, de performance de chauffage, de vos contraintes d'implantation, de vos contraintes budgétaires...
- Pour vous accompagner à toutes les étapes de votre projet car il bénéficie de l'appui permanent des équipes du bureau d'étude et de l'usine de fabrication de Chazelles,
- Pour vous informer sur les normes de sécurité, les avantages fiscaux, et vous proposer des solutions de financement,
- Pour répondre à vos interrogations même après l'installation de votre projet.

...ET DANS LE MONDE

Chazelles connaît un très fort développement à l'international. Notre marque est présente dans une trentaine de pays, en Europe, Afrique du nord, Moyen Orient, Russie et Australie. Des gammes spécifiques de produits y sont exportées, avec un succès croissant, tant pour les cheminées que pour les appareils de chauffage. Cette distribution internationale contribue fortement au rayonnement de Chazelles.

IN FRANCE...

Chazelles network represents over 110 professionals throughout the national territory.

Your Chazelles dealer is not just a reseller but a qualified professional who will help you to take advantage of its expertise to offer you all Chazelles services:

- To give you the best advice for choosing your fireplace or your insert, depending on your expectations: design, heating performance, location constraints, budget ...
- To help you at every stage of your project he benefits from the support teams of the Chazelles office and factory team.
- To inform you about safety standards and offer you financing solutions.
- To answer to your questions even after the installation of your project.

...AND WORLDWIDE

Chazelles is currently undergoing a very strong international development. Our brand is present in thirty countries in Europe, North Africa, Middle East, Russia and Australia. Specific ranges of products are exported, with a growing success for fireplaces as well as heating appliances. This international network contributes significantly to the reputation of Chazelles.

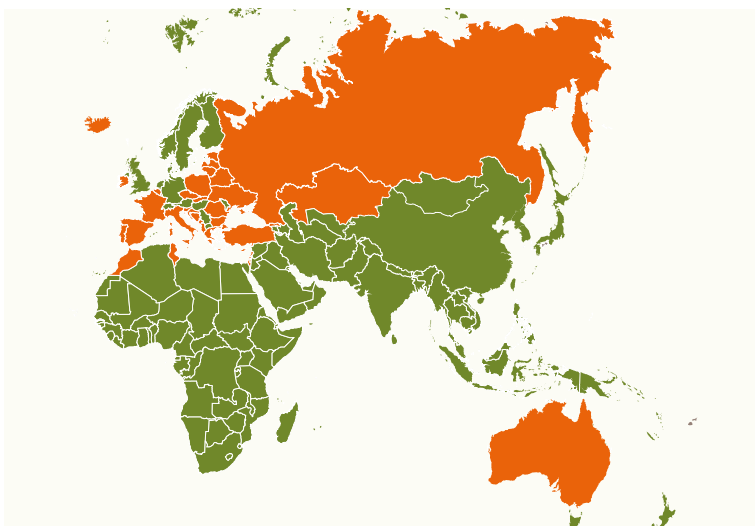

Pour connaître le concessionnaire Chazelles le plus proche de chez vous, consultez notre site internet :

To locate the nearest dealer, visit our website :

www.chazelles.com



LA QUALITÉ

D'UN SERVICE PERSONNALISÉ

THE QUALITY OF PERSONALIZED SERVICE

PERSONNALISEZ VOTRE ESPACE

CUSTOMIZE YOUR OWN SPACE

PARMI UN LARGE CHOIX DE PLUS DE 1500 POSSIBILITÉS
AMONG A LARGE CHOICE OF MORE THAN 1500 COMBINATIONS.

Composez en toute liberté votre façade de chauffage. Personnalisez votre insert avec l'épaisseur d'encadrement de votre choix et le modèle de niche à bois qui s'harmonisera au mieux avec votre espace de vie.

Create your own front. Customize your insert with the desired frame and wood niche model that will match the best with your living space.

1

Choix de l'insert

Insert choice



Compatibilité : toutes les gammes d'inserts

Compatibility: all insert ranges

2

Choix du cadre

Frame choice

S
20 mm



Inserts à granulés + Inserts bois
Pellet inserts + wood inserts

L
50 mm



Inserts bois en fonte
Castiron wood inserts

3

Choix de la niche à bois

Wood niche choice

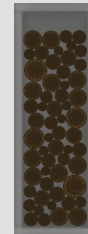

Grand modèle
Large model

L (W) = 450 mm
H (H) = 1296 mm
P (D) = 555 mm



Petit modèle
Small model

L (W) = 450 mm
H (H) = 896 mm
P (D) = 555 mm

EXEMPLE DE COMPOSITION

EXAMPLE OF COMPOSITION

Si parmi tous les modèles de notre catalogue à personnaliser vous ne trouvez pas ce que vous désirez, consultez nos spécialistes du sur mesure.

Vérifiez la compatibilité auprès de votre revendeur Chazelles.

If you don't find what you wish from our models consult our experts of custom-made.
Check compatibility with your dealer Chazelles.

1

Insert HP 700
HP 700 Insert



2

Vintage pour insert HP
Vintage for HP insert

3

Niche
petit modèle
Wood niche
small model





Chazelles

LEADER DU SUR-MESURE DEPUIS PLUS DE
30 ANS

LEADER OF CUSTOM-MADE FOR OVER 30 YEARS



RÊVEZ VOTRE INTÉRIEUR

DREAM YOUR INTERIOR

1

IMAGINEZ

IMAGINE

Pensez, discutez, dessinez,
visualisez le design de vos
rêves...

Think, exchange, draw, visualize...



2

CHOISISSEZ VOTRE UNIVERS & PERSONNALISEZ

CHOOSE YOUR STYLE & CUSTOMIZE

Laissez libre cours à votre
imagination.
Concevez votre espace à
vivre Chazelles.

*Give your imagination free reins, and
design your own living space with
Chazelles.*

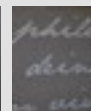
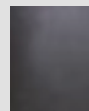
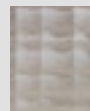
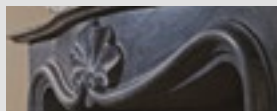

Style, forme,
matières, couleurs...
Style, Shape, Material, Colour...

3

ADAPTEZ À VOTRE ESPACE

ADAPT TO YOUR HOME

Profitez de l'expérience Chazelles !

Enjoy The Chazelles experience !







LES CHEMINÉES

FIREPLACES

Contemporaines - Antiquaires - Classiques
Rustiques - Essentielles - Métaux

Contemporary - Antic - Classic
Rustic - Essential - Metal

CONTEMPORAINES

CONTEMPORARY





CS 50



Cheminée encastrée cadre en roche bleue.
Built in fireplace with frame in blue rock.

Combustibles cheminée :



| DIMENSIONS (mm) | | |
|-----------------|--------|--------|
| DIMENSIONS | | |
| L W | P D | H H |
| 1410 | 80 | 685 |



Cheminée encastrée cadre en granit noir antique.

Built-in fireplace with frame in antic black granite.

Combustibles cheminée :



DIMENSIONS (mm)
DIMENSIONS

| L W | P D | H H |
|--------|--------|--------|
| 1318 | 821 | 600 |



Compatible : Facel 800 VAD



LAZORE



Cheminée semi-encastée cadre en acier et plateau en ardoise.

Option : tiroir en façade.

Semi built-in fireplace with steel frame and bench in slate. Option : front drawer

Combustibles cheminée :



DIMENSIONS (mm)
DIMENSIONS

| L W | P D | H H |
|--------|--------|--------|
| 1641 | 1015 | 551 |



Compatible : Facel 800 VAD



TIVOLI



BALISIET



Cheminée semi-encastree en roche bleue et en roche noire.

Semi built-in fireplace in blue and black rock.

Combustibles cheminée :



DIMENSIONS (mm)
DIMENSIONS

| L W | P D | H H |
|--------|--------|--------|
| 2579 | 545 | 970 |



Compatible : Facel 800



BRISE

Cheminée encastree en granit noir Zimbabwe.

Built-in fireplace in Zimbabwe black granite.

Combustibles cheminée :



DIMENSIONS (mm)
DIMENSIONS

| L W | P D | H H |
|--------|--------|--------|
| 1390 | 5 | 525 |



Compatible : Cloud 100 R



FOREST ANGLE

Avec son design moderne et élégant, la Forest Angle embellira votre intérieur. Aussi pratique qu'esthétique, elle vous offrira une belle vue sur les flammes.

With its modern and elegant design, the Forest Angle will embellish your interior. As practical as it is aesthetic, it will offer you a beautiful view of the flames



Cheminée semi encastrée cadre en marbre wengé et en ardoise.
Semi built-in fireplace with frame in Wengé marble and slate. Combustible / Fuel



Compatible : Cloud 70 R



7★

Dimensions cadre / Frame Dimensions

965 x 580 x 750 mm (L x P x H)

Combustibles / Fuel



MERCURIALE

Profitez d'un panorama de vos flammes avec le MERCURIALE. Cette cheminée est en granit noir Zimbabwe avec un effet cuir.

Enjoy a panorama of your flames with the MERCURIALE fireplace. This fireplace is made of black Zimbabwe granite with a leather effect.



Cheminée encastrée cadre en granit noir effet cuir.
Built in fireplace with frame in black granite with leather effect.

Dimensions cadre / Frame Dimensions

1850 x 20 x 505 mm (L x P x H)

Combustibles / Fuel



Compatible : VE 1000



Cheminée de face en roche noire avec banquette intégrée. Modèle réversible droite ou gauche.

Full front fireplace made in black rock with bench. Reversible model right or left.

Dim. Banquette. / Bench size :

Combustibles cheminée :



| DIMENSIONS (mm) DIMENSIONS | | |
|-------------------------------|--------|--------|
| L W | P D | H H |
| 970 | 30 | 744 |

Dim. Banquette :

730 (L) x 650 (P) x 500 (H) x 80 (EP) mm

Dench Dim. : 730 (W) x 650 (D) x 500 (H) x 80 (T) mm

Option niche Dim. : 450 (L) x 555 (P) x 896 (H) mm

Niche option Dim. : 450 (L) x 555 (P) x 896 (H) mm



Compatible : HP 700



ALINÉA

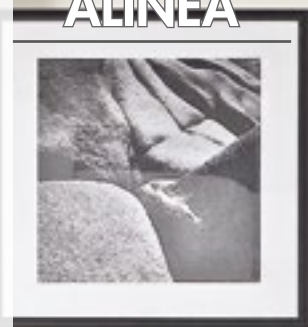

Cheminée semi-encastrée avec cadre en acier brossé vernis avec niche à bois assortie.

Semi build in fireplace and wood niche in brushed and varnished steel.

Combustibles cheminée :



| DIMENSIONS (mm) DIMENSIONS | | |
|-------------------------------|--------|--------|
| L W | P D | H H |
| 1105 | 20 | 935 |

Option niche Dim. : 450 x 935 mm



Compatible : HP 700



VINTAGE



YOKO

Cheminée encastrée en marbre déco polaire brillant.

Built-in fireplace in shining polar decorative marble.

Combustibles cheminée :



DIMENSIONS (mm)
DIMENSIONS

| L W | P D | H H |
|--------|--------|--------|
| 1290 | 20 | 790 |



Compatible : VE 1000



ZEN

Cheminée semi-encastrée en roche noire.

Option : banquette.

Semi built-in fireplace made in black rock, optional bench.

Combustibles cheminée :



DIMENSIONS (mm)
DIMENSIONS

| L W | P D | H H |
|--------|--------|--------|
| 772 | 20 | 777 |



Compatible : IQ33



Cheminée semi-encastrée avec cadre en granit noir sablé.

Semi built-in fireplace, with a frame in sanded black granite.

Combustibles cheminée :



| DIMENSIONS (mm) | | |
|-----------------|--------|--------|
| DIMENSIONS | | |
| L W | P D | H H |
| 835 | 20 | 865 |



Compatible : IQ33



MOSAÏQUE



Cheminée encastrée en marbre déco polaire brillant incrustée de cabochons en chêne huilé.

Built-in fireplace made in decorative marble with ornament oiled oak.

Combustibles cheminée :



| DIMENSIONS (mm) | | |
|-----------------|--------|--------|
| DIMENSIONS | | |
| L W | P D | H H |
| 1450 | 20 | 880 |



Compatible : Cloud 100 R Horizon



GLAM





TOPAZE

Cheminée semi-encastrée avec cadre en acier finition béton ciré.

Semi built-in fireplace with steel frame in polished concrete finish.

Combustibles cheminée :



DIMENSIONS (mm)
DIMENSIONS

| L W | P D | H H |
|--------|--------|--------|
| 1290 | 20 | 790 |



COTTAGE

Cheminée de face en marbre déco cappuccino et pierre de Chazelles.

Full front fireplace, cappuccino decorative marble and Chazelles stone.

Combustibles cheminée :



DIMENSIONS (mm)
DIMENSIONS

| L W | P D | H H |
|--------|--------|--------|
| 1800 | 640 | 970 |



Compatible : Cloud 90 3V



Cheminée encastrée en pierre d'Estailades et roche bleue.

Built-in fireplace in Estailade stone and blue rock.

Combustibles cheminée :



DIMENSIONS (mm)
DIMENSIONS

| L W | P D | H H |
|--------|--------|--------|
| 1240 | 750 | 850 |

MELBOURNE



Visuel : Cloud 90 3V



Cheminée encastrée en pierre de Mauzens. Finition sous insert en marbre déco prune brillant. Option : niche à bois en acier anthracite.

Built-in fireplace in Mauzens stone, finishing under the insert in shining plum decorative marble.

Option : wood niche in anthracite steel

Combustibles cheminée :



DIMENSIONS (mm)
DIMENSIONS

| L W | P D | H H |
|--------|--------|--------|
| 130 | 90 | 850 |

SEATTLE



Compatible : HP 700



BALTIMORE

Cheminée de face en pierre d'Estailades et roche noire.
Full front fireplace in Estailades stone and black rock.

Combustibles cheminée :



DIMENSIONS (mm)
DIMENSIONS

| L W | P D | H H |
|--------|--------|--------|
| 1300 | 840 | 1120 |



Compatible : Cloud 90 3V



OPUS

Cheminée de face en pierre d'Estailades. Finition sous insert en marbre. Chocolat brossé.
Full front fireplace in Estailade stone. Finishing under the insert in brushed chocolate marble.

Full front fireplace in Estailade stone. Finishing under the insert in brushed chocolate marble.

Combustibles cheminée :



DIMENSIONS (mm)
DIMENSIONS

| L W | P D | H H |
|--------|--------|--------|
| 2310 | 630 | 1090 |



Compatible : HP 700



Bûcher : dimensions intérieures : 51 x 57 x 33 cm.
Deux compartiments de rangement de chaque côté : Dimensions extérieures :
Droite : 60 x 57 x 45 cm
Gauche : 80 x 57 x 55 cm.

Wood niche : inside dimensions : 51 x 57 x 33cm.

Two storage boxes on each side (outside dimensions :

right : 60 x 57 x 45 cm
- left : 80 x 57 x 55 cm)

Cheminée semi-encastrée avec cadre en acier découpé.

Semi built-in fireplace with steel cut frame.

COSMOPOLITE

Combustibles cheminée :



DIMENSIONS (mm)
DIMENSIONS

| L W | P D | H H |
|--------|--------|--------|
| 1037 | 5 | 891 |



Cheminée semi-encastrée en pierre d'Estailades et roche noire.

Semi built-in fireplace, Estailades stone and black rock

CITY

Combustibles cheminée :



DIMENSIONS (mm)
DIMENSIONS

| L W | P D | H H |
|--------|--------|--------|
| 1210 | 350 | 1080 |



LODGE

Cheminée semi-encastrée en pierre d'Estailades et roche bleue.

Semi built-in fireplace, Estailades stone and blue rock.

Combustibles cheminée :



DIMENSIONS (mm)
DIMENSIONS

| L W | P D | H H |
|--------|--------|--------|
| 1380 | 100 | 250 |



Compatible : Cloud 100 R



MALTE

Cheminée semi-encastrée en pierre d'Estailades et roche bleue.

Semi built-in fireplace, Estailades stone and blue rock.

Combustibles cheminée :



DIMENSIONS (mm)
DIMENSIONS

| L W | P D | H H |
|--------|--------|--------|
| 1280 | 380 | 1160 |



Compatible : Cloud 100 R



VENICE

Optez pour cette sublime cheminée encastrée qui s'accompagne d'un contour en pierre de Doura. Cette cheminée est également disponible en roche bleue. D'un design unique et moderne, VENICE est un modèle très apprécié par son esthétisme.

Opt for this sublime built-in fireplace with a Doura stone surround. This fireplace is also available in blue rock. With its unique and modern design, VENICE is a model that is highly appreciated for its aestheticism.



Cheminée encastrée cadre en pierre de doura
disponible en roche bleue.

*Built in fireplace with frame in doura stone also
available in blue rock.*



Compatible : HP 700

Dimensions cadre / Frame Dimensions

905 x 100 x 655 mm (L x P x H)

Combustibles / Fuel



SEOUL

Cette sublime cheminée contemporaine en pierre d'Estailades et en roche noire dispose d'un encadré en acier noir offrant un effet très tendance au produit. Très pratique, cet habillage est équipé d'un tiroir à accessoires.

This sublime contemporary fireplace in Estailades stone and black rock has a black steel frame offering a very trendy effect to the product. Very practical, this surround is equipped with an accessory drawer.



SEOUL

Tiroir à accessoires intégré.
Dimensions intérieures :
34 x 54 x 33 cm.
Dimensions extérieures :
58,5 x 60 x 37,5 cm.

*Drawer for accessories:
Internal dimensions :
34 x 54 x 33
External dimensions :
58,5 x 60 x 37,5 cm*

Cheminée de face en pierre d'Estailades et roche noire avec cadre en acier noir.

Full front fireplace in Estailades stone and black rock with black steel frame.



Compatible : HP 700

Dimensions cadre / Frame Dimensions

1780 x 760 x 1060 mm (L x P x H)

Combustibles / Fuel



Cheminée encastrée en pierre d'Estailades et marbre déco cappuccino.

Built-in fireplace in Estailades stone and Cappuccino decorative marble.

Combustibles cheminée :



DIMENSIONS (mm)
DIMENSIONS

| L W | P D | H H |
|--------|--------|--------|
| 1070 | 540 | 850 |



Compatible : Cloud 90 VAD



ATLANTA



Cheminée semi-encastée en marbre anthracite brossé.

Semi built-in fireplace made in anthracite brushed marble.

Combustibles cheminée :



DIMENSIONS (mm)
DIMENSIONS

| L W | P D | H H |
|--------|--------|--------|
| 1620 | 160 | 630 |



Compatible : Cloud 130 R



ANTALYA



BOAT

Cheminée semi-encastrée avec encadrement tech et filets blancs. En pierre de Chazelles.

Semi built-in fireplace, teak frame, white lines, Chazelles stone.

Combustibles cheminée :



DIMENSIONS (mm)
DIMENSIONS

| L W | P D | H H |
|--------|--------|--------|
| 2140 | 840 | 1180 |



Compatible : Cloud 130 R



ULTIMATE

Cheminée de face en marbre déco anthracite et gris brossé.

3-sided full front fireplace, brushed anthracite and brushed grey decorative marble.

Combustibles cheminée :



DIMENSIONS (mm)
DIMENSIONS

| L W | P D | H H |
|--------|--------|--------|
| 1380 | 670 | 900 |



Compatible : Cloud 70 3 V



Cheminée avec cadre en acier noir droit.

Black steel straight frame.

QUIBERON

Combustibles cheminée :



DIMENSIONS (mm)
DIMENSIONS

| L <i>W</i> | P <i>D</i> | H <i>H</i> |
|---------------|---------------|---------------|
| 1000 | 20 | 790 |



Compatible : HP 700



Cheminée semi-encastrée avec cadre en pierre de Doura.

Semi built-in fireplace with frame made in Doura stone.

RIVOLI

Combustibles cheminée :



DIMENSIONS (mm)
DIMENSIONS

| L <i>W</i> | P <i>D</i> | H <i>H</i> |
|---------------|---------------|---------------|
| 680 | 28 | 680 |



Compatible : IQ33



LINÉA

Cheminée semi-encastrée en pierre bleue. Décor lisse en bas relief. Soubassement et entourage acier noir.

Semi built-in fireplace, blue stone, smooth bas-relief decor, underframe and frame in black steel.

Combustibles cheminée :



DIMENSIONS (mm)
DIMENSIONS

| L W | P D | H H |
|--------|--------|--------|
| 1760 | 120 | 980 |



Compatible : Cloud 130 R



GRAPHITE

Cheminée semi-encastrée avec cadre en acier et finition en ardoise.

Semi built-in fireplace with steel and slate frame.

Combustibles cheminée :



DIMENSIONS (mm)
DIMENSIONS

| L W | P D | H H |
|--------|--------|--------|
| 1115 | 40 | 815 |

Cheminée semi-encastée en roche noire décorée de hiéroglyphes.

Semi built-in fireplace decorated with hieroglyphs, black rock.

Combustibles cheminée :



DIMENSIONS (mm)
DIMENSIONS

| L <i>W</i> | P <i>D</i> | H <i>H</i> |
|---------------|---------------|---------------|
| 1395 | 30 | 128 |



Visuel : Cloud 100 R



RAMSES NOIRE



Cheminée semi-encastée avec cadre 16/9 ème en pierre de Chazelles.

Semi built-in fireplace, Chazelles stone, 16:9 frame.

Combustibles cheminée :



DIMENSIONS (mm)
DIMENSIONS

| L <i>W</i> | P <i>D</i> | H <i>H</i> |
|---------------|---------------|---------------|
| 1570 | 10 | 550 |



Visuel : Cloud 100 R Horizon



VISION



RAMSES SABLE

Cheminée semi-encastrée en pierre de Martigny décorée de hiéroglyphes.

Semi built-in fireplace decorated with hieroglyphs, Martigny stone.

Combustibles cheminée :



DIMENSIONS (mm)
DIMENSIONS

| L W | P D | H H |
|--------|--------|--------|
| 1395 | 30 | 1280 |



Visuel : Facel 800



LOUISE

Cheminée semi-encastrée en marbre avec déco noir pailleté. Miroir assorti.

Semi built-in fireplace, spangled black decorative marble, matching mirror.

Combustibles cheminée :



DIMENSIONS (mm)
DIMENSIONS

| L W | P D | H H |
|--------|--------|--------|
| 1610 | 160 | 1770 |



Visuel : Sweetline 100



Cheminée avec cadre en inox brossé droit.

Straight brushed stainless steel frame.

Combustibles cheminée :



DIMENSIONS (mm)
DIMENSIONS

| L <i>W</i> | P <i>D</i> | H <i>H</i> |
|---------------|---------------|---------------|
| 1410 | 20 | 780 |

PORNICHET

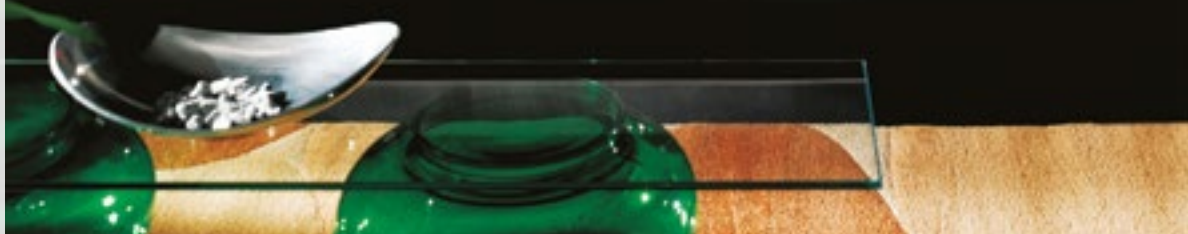

Compatible : Cloud 120 R DF Horizon



Cheminée encastrée en pierre d'Estailades.

Built-in fireplace, Estailades stone.

Combustibles cheminée :



DIMENSIONS (mm)
DIMENSIONS

| L <i>W</i> | P <i>D</i> | H <i>H</i> |
|---------------|---------------|---------------|
| 1040 | 120 | 820 |

OLORON



BIARRITZ

Cheminée encastrée en acier noir.
Black steel frame.



Combustibles cheminée :



DIMENSIONS (mm)
DIMENSIONS

| L W | P D | H H |
|--------|--------|--------|
| 1600 | 20 | 820 |



Compatible : Cloud 100 R



GALET

Cheminée encastrée en marbre avec
déco anthracite brossé. Décor lisse
en bas relief.

Built-in fireplace, brushed anthracite decorative marble, smooth bas-relief decor.

Combustibles cheminée :



DIMENSIONS (mm)
DIMENSIONS

| L W | P D | H H |
|--------|--------|--------|
| 1960 | 30 | 1100 |



Compatible : Cloud 100 R



Cheminée encastrée en pierre de
Chazelles.

Built-in fireplace, Chazelles stone.

ORSAY

Combustibles cheminée :



| DIMENSIONS (mm) | | |
|-----------------|--------|--------|
| DIMENSIONS | | |
| L W | P D | H H |
| 1240 | 50 | 940 |



Visuel : HP 700



Cheminée encastrée avec cadre en
ardoise.

Built-in fireplace, slate frame.

YOUNG

Combustibles cheminée :



| DIMENSIONS (mm) | | |
|-----------------|--------|--------|
| DIMENSIONS | | |
| L W | P D | H H |
| 101 | 2 | 113 |



Compatible : Sweetline 80



CALGARY 530

Cheminée encastrée avec cadre en pierre d'Estailades. Finition sous insert en ardoise.

Built-in fireplace with frame in Estailades stone. Finishing under the insert in slate.

Combustibles cheminée :



DIMENSIONS (mm)
DIMENSIONS

| L W | P D | H H |
|--------|--------|--------|
| 740 | 170 | 765 |



Compatible : IQ33



CALGARY

Cheminée encastrée avec cadre en pierre d'Estailades. Finition sous insert en ardoise.

Built-in fireplace with frame in Estailades stone. Finishing under the insert in slate.

Combustibles cheminée :



DIMENSIONS (mm)
DIMENSIONS

| L W | P D | H H |
|--------|--------|--------|
| 910 | 170 | 760 |



Compatible : HP 700



ANTIQUAIRES

ANTIC

PLESSIS



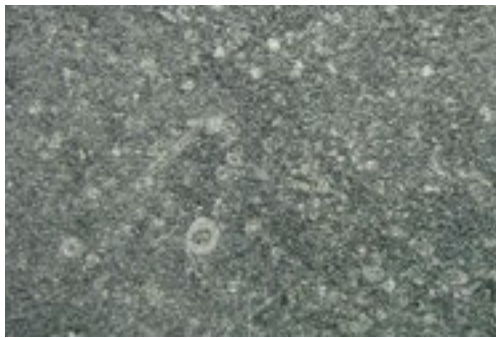

Cheminée semi-encastée en pierre bleue adoucie.

Semi built-in fireplace made in softened blue stone.

Combustibles cheminée :



DIMENSIONS (mm)
DIMENSIONS

| L W | P D | H H |
|--------|--------|--------|
| 1350 | 500 | 1020 |



Compatible : Cloud 100 R



MÉNARDIÈRE



Cheminée avec hotte de tradition en pierre de Fontbelle vieillie et patinée. Hauteur sur linteau : 104 cm.
Fireplace with traditional hood in aged and patinated Fontbelle stone.

Dimensions cadre / Frame Dimensions

1310 x 440 x 2260 mm (L x P x H)

Combustibles / Fuel



LOGIS

Cheminée avec hotte classique en pierre de Bourgogne dorée, vieillie, cirée. Briquettes de 5 sable, moulées main, sur simple socle. Hauteur sur linteau : 111 cm et foyer ouvert de 95 cm.

Fireplace with classic hood in aged and patinated gilded Burgundy stone. 5-sand bricks had molded on a single base.

Hight to lintel : 111 cm. Open hearth 95 cm.

Combustibles cheminée :



DIMENSIONS (mm)
DIMENSIONS

| L W | P D | H H |
|--------|--------|--------|
| 1350 | 440 | 2330 |

LOGIS SANS HOTTE

Cheminée semi-encastrée sur simple socle en pierre de Bourgogne dorée, vieillie et cirée. Briquettes de 5 sable moulée main. Foyer ouvert de 95 cm.

Fireplace in aged and patinated gilded Burgundy stone. 5-sand bricks had molded on a single base. Open hearth 95 cm.

Combustibles cheminée :



DIMENSIONS (mm)
DIMENSIONS

| L W | P D | H H |
|--------|--------|--------|
| 1350 | 440 | 1110 |

Cheminée en pierre blanche dorée,
vieille et patinée.

Fireplace in aged and patinated gilded
white stone.

Combustibles cheminée :



DIMENSIONS (mm)
DIMENSIONS

| L W | P D | H H |
|--------|--------|--------|
| 1310 | 440 | 1040 |



Cheminée en pierre blonde vieillie et
patinée.

Fireplace aged and patinated gilded blond
stone.

Combustibles cheminée :



DIMENSIONS (mm)
DIMENSIONS

| L W | P D | H H |
|--------|--------|--------|
| 1310 | 440 | 1040 |



LONGÈRE

Cheminée en pierre de Bourgogne dorée et cirée.

Fireplace in aged and patinated gilded Burgundy stone.

Combustibles cheminée :



DIMENSIONS (mm)
DIMENSIONS

| L W | P D | H H |
|--------|--------|--------|
| 1310 | 440 | 1040 |



CHAUVIÈRE

Cheminée en pierre blonde, vieillie et patinée.

Fireplace in aged and patinated gilded blond stone.

Combustibles cheminée :



DIMENSIONS (mm)
DIMENSIONS

| L W | P D | H H |
|--------|--------|--------|
| 1310 | 440 | 1040 |



CLASSIQUES

CLASSIC

Cheminée semi-encastrée en pierre de Doura. Briquettes de 3 rouge flammé et joints blancs.

Semi built-in fireplace made in Doura stone and 3-stippled red bricks with white joints.

Combustibles cheminée :



DIMENSIONS (mm)
DIMENSIONS

| L W | P D | H H |
|--------|--------|--------|
| 1370 | 450 | 950 |



Compatible : Cloud 100 R



MARQUISE





RAMBOUILLET

Cheminée semi-encastée en Pierre de Brétignac

Semi built-in fireplace in Brétignac stone.

Combustibles cheminée :



DIMENSIONS (mm)
DIMENSIONS

| L W | P D | H H |
|--------|--------|--------|
| 1220 | 300 | 1100 |



Compatible : HP 700



Cheminée semi-encastée en pierre de Bourgogne dorée avec mérisier massif. Briquettes de 3 avec joints blancs. Hauteur sur linteau de 103 cm. Foyer ouvert de 71 x 54 cm.

Semi Built-in Cherry wood Burgundy stone, bricks white joints. Height to lintel : 103 cm. Open fireplace 71 x 54 cm.

Combustibles cheminée :



DIMENSIONS (mm)
DIMENSIONS

| L W | P D | H H |
|--------|--------|--------|
| 1450 | 300 | 1030 |



TERREFORT

Cheminée de face en pierre blanche ramagée. Briquettes de 5 jaune flammé avec joints blancs. Hauteur sur linteau de 147 cm. Foyer ouvert de 88 x 74 cm.

Full front fireplace, white fossil-encrusted stone, 5 stippled yellow, white joints.

Combustibles cheminée :



DIMENSIONS (mm)
DIMENSIONS

| L W | P D | H H |
|--------|--------|--------|
| 1440 | 910 | 2500 |



ROCHEFOUCAULT



Cheminée de face en pierre de Brétignac. Briquettes de 5 cevennes avec motif et joints clairs. Hauteur sur linteau 132 cm. Foyer ouvert de 102 x 85 cm.

Full front fireplace, Bretignac stone, Bricks 5 Cevennes style, clear joints, height to lintel 132 cm, open fireplace, 102 x 85 cm.

Combustible cheminée :



DIMENSIONS (mm)
DIMENSIONS

| L W | P D | H H |
|--------|--------|--------|
| 1680 | 850 | 2500 |

CHENEVIÈRE



Cheminée semi-encastree en pierre de Brétignac avec double socle en pierre de Chazelles. Briques de 5 moulées main. Hauteur sur linteau de 126 cm. Foyer ouvert de 110 x 85 cm.

Semi built-in fireplace, Bretignac stone, Double base of Chazelles stone, 5 hand-molded bricks. Height to lintel : 126 cm, open fireplace 110 x 85 cm.

Combustibles cheminée :



DIMENSIONS (mm)
DIMENSIONS

| L W | P D | H H |
|--------|--------|--------|
| 1640 | 440 | 2500 |

RUSTIQUES

RUSTIC





BRILLAC

Cheminée semi-encastée en pierre de Mauzens. Briquettes de 5 sable moulées main et poutre galbée en chêne naturel.
Semi built-in fireplace, Mauzens stone, 5 sand-bricks hand molded, curved natural oak beam.

Combustibles cheminée :



| DIMENSIONS (mm) | | |
|-----------------|--------|--------|
| DIMENSIONS | | |
| L W | P D | H H |
| 1290 | 140 | 1280 |



Compatible avec :
HP 700



Cheminée de face en pierre de montagne et pierre de Bourgogne dorée. Briquettes de 5 sable moulées main. Poutre en chêne naturel.

3-sided full front fireplace, mountain stone, golden Burgundy stone and 6 sand-bricks hand molded, natural oak beam.

Combustibles cheminée :



DIMENSIONS (mm)
DIMENSIONS

| L <i>W</i> | P <i>D</i> | H <i>H</i> |
|---------------|---------------|---------------|
| 1550 | 910 | 1220 |



Compatible avec
Cloud 90 3V



ECHOISY



VILHONNEUR

Cheminée en pierre de Brétignac.
Briques de 5 sable moulées main.
Poutre en chêne.

*Full front fireplace, Brétignac stone, Sand-
bricks hand molded, oak beam.*

Combustibles cheminée :



DIMENSIONS (mm)
DIMENSIONS

| L W | P D | H H |
|--------|--------|--------|
| 1500 | 890 | 1210 |



VILHONNEUR AVEC COMPTOIR

Cheminée de Brétignac. Briquettes de 5 sable moulée main. Menuiserie en chêne et plaqué chêne. Grandes niches avec étagères en applique contre mur. Dim. 250 x 20 x 250 cm.

Fireplace in Brétignac stone, 5 sand-bricks hand molded, oak woodwork, large niches with wall-mounted shelves. Dims : 250 x 20 x250 cm.

Combustibles cheminée :



DIMENSIONS (mm)
DIMENSIONS

| L W | P D | H H |
|--------|--------|--------|
| 3060 | 250 | 2260 |



ESSENTIELLES

ESSENTIAL



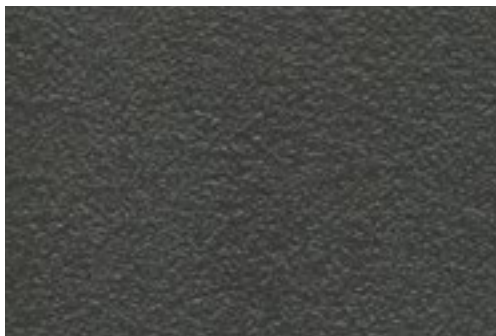

CS 41

Cheminée en pierre de Brétignac et en roche noire.

Fireplace in Bretonnais stone and black rock.

Combustibles cheminée :



DIMENSIONS (mm)
DIMENSIONS

| L W | P D | H H |
|--------|--------|--------|
| 890 | 70 | 740 |

Pierre réversible



Compatible avec
HP700



CS 48

La CS48 est la cheminée parfaite qui s'adaptera à beaucoup d'inserts. C'est un produit économique au format optimisé qui saura combler vos attentes.

The CS48 is the perfect fireplace which that will fit many inserts. It is an economical product with an optimized format which will meet your expectations.

CS 48



Cheminée avec cadre en acier noir disponible en taille S (20mm) ou en taille L (50mm).

Fireplace with black steel frame available in 'S' size (20mm) and 'L' size (50 cm).



Compatible avec
HP700

Dimensions cadre / Frame Dimensions

850 x 20 x 600 mm (L x P x H)

Combustibles / Fuel



CS 42



Cheminée en pierre de Brétignac et
roche bleue.
Fireplace in Bretignac stone and blue rock.

Combustibles cheminée :



DIMENSIONS (mm)
DIMENSIONS

| L W | P D | H H |
|--------|--------|--------|
| 1020 | 50 | 800 |

Pierre réversible



Compatible avec :
HP 700



CS 43



Cheminée en pierre de Brétignac et
en roche bleue.
Fireplace in Bretignac stone and blue rock.

Combustibles cheminée :



DIMENSIONS (mm)
DIMENSIONS

| L W | P D | H H |
|--------|--------|--------|
| 1110 | 60 | 700 |

Pierre réversible

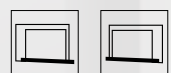

Compatible avec
HP700







LES INSERTS

Granulés - Bois - Hydro - Gaz
Pellet - Wood - Hydro - Gas

GRANULÉS

PELLET

FACEL 500 EVO

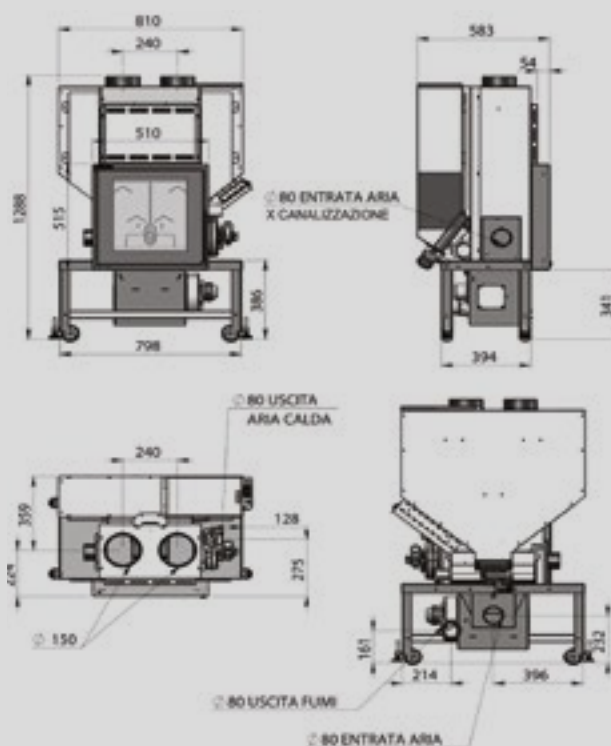

CALGARY



Insert à granulés en acier avec vitre sérigraphiée et intérieur en vermiculite. Canalisé avec double brûleur et clapet anti-surpression.

Steel pellet insert with screen-printed glass and vermiculite combustion chamber. It is equipped with a double burner and a pressure relief valve.

Dimensions / Dimensions **810 x 583 x 1288 mm (L x P x H)**

Combustible / Fuel



Puissance / Power

10,7 kW

Classe énergétique / Energy Class

A+

Rendement énergétique (min/max) / Efficiency

91.9 / 90.3 %



Canalisé



FACEL 500 VERTICAL

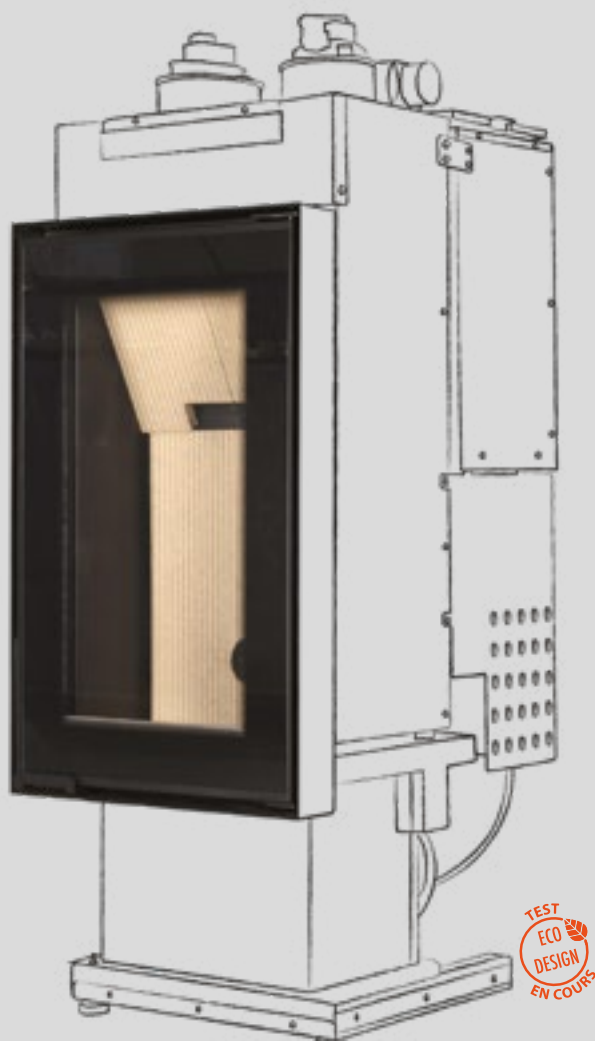
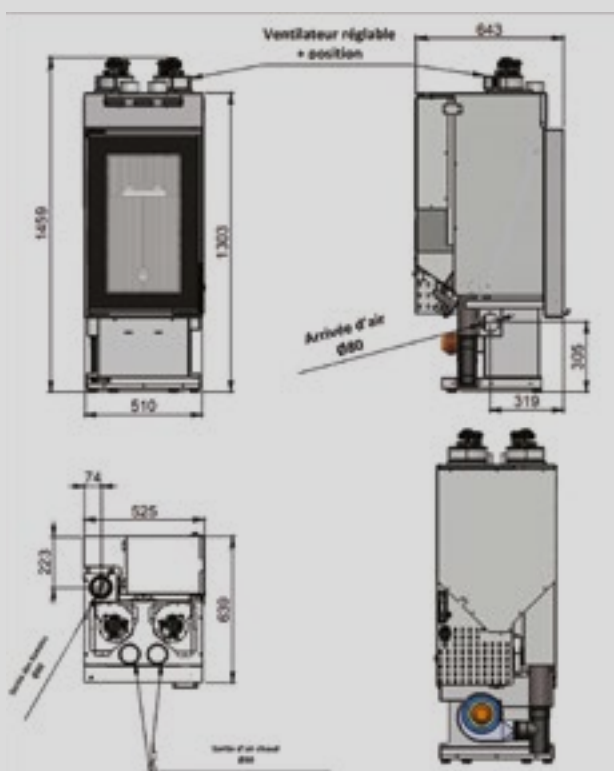

Insert à granulés confectionné en acier avec sa longue vitre apparente (compatible au WIFI). Canalisé avec double brûleur et clapet anti-surpression.

Steel pellet insert with a long visible window. (Wifi compatible). It is equipped with a double burner and a pressure relief valve.

Dimensions / Dimensions **510 x 640x 1460 mm (L x P x H)**

Combustible / Fuel



Puissance / Power **13,8 kW**

Classe énergétique / Energy class **A+**

Rendement énergétique (min/max) / Efficiency **93.8 / 88.4 %**



Canalisé



INSERTS GRANULÉS

Insert en acier avec réservoir étanche et système d'alimentation. Vitre sérigraphiée 16/9 et intérieur en vermiculite. Canalisé avec double brûleur. Sonde de température. Télécommande radio avec sonde de température intégrée et clapet anti-surpression.

Steel pellet insert with a tight tank and a feeding system. 16/9 Screen printed glass. Vermiculite combustion chamber. Channelled with a double burner. Remote control with temperature probe and anti over-pressure valve.

 **13 kW**



DIMENSIONS (mm)
DIMENSIONS

| L W | P D | H H |
|--------|--------|--------|
| 1200 | 800 | 1600 |



Rendement énergétique
(min / max) : 91.9 / 90.3

Classe énergétique : **A+**

FACEL 800 EVO

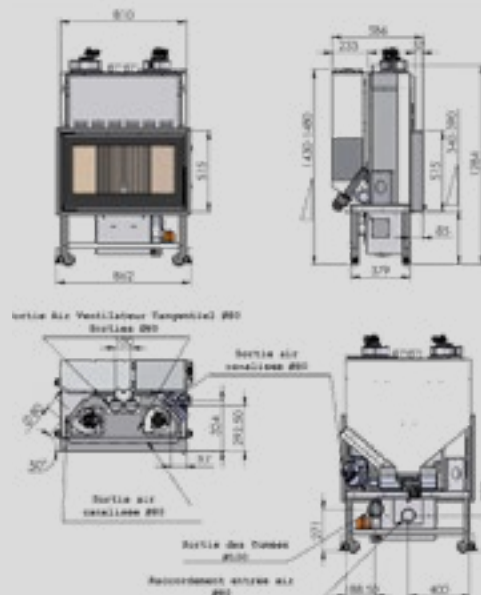
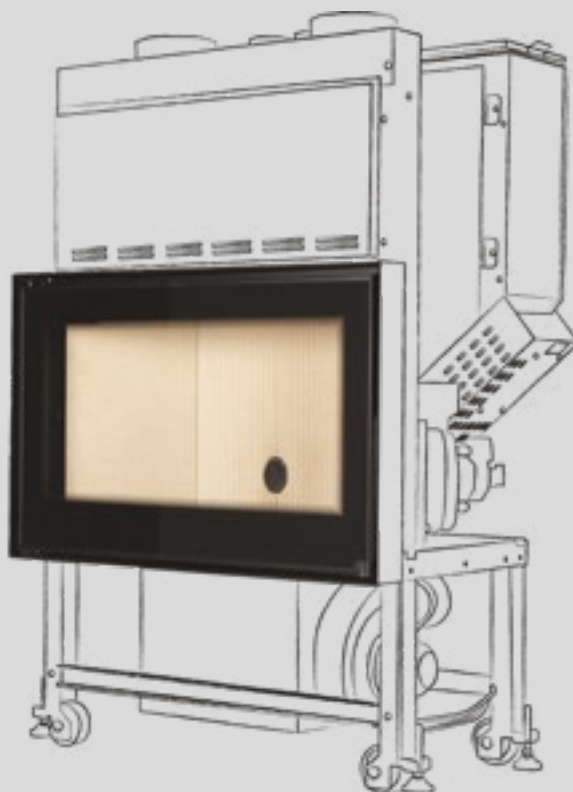

Insert en acier avec réservoir intégré et système d'alimentation. Vitre sérigraphiée et intérieur en vermiculite.

Canalisé avec double brûleur et sonde de température. Télécommande radio avec sonde de température intégrée. Clapet anti-surpression.

Steel pellet insert with an integrated tank and a feeding system. Screen printed glass, vermiculite combustion chamber. Channelled with a double burner. Remote control with temperature probe and anti over-pressure valve.

 **14 kW**



DIMENSIONS (mm)
DIMENSIONS

| L W | P D | H H |
|--------|--------|--------|
| 797 | 732 | 1456 |

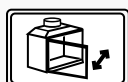

Classe énergétique : **A+**

FACEL 800 VAD-VAG

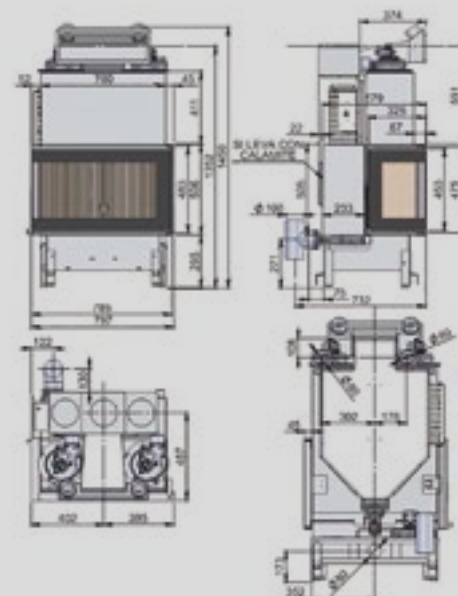





FACEL 800 3V

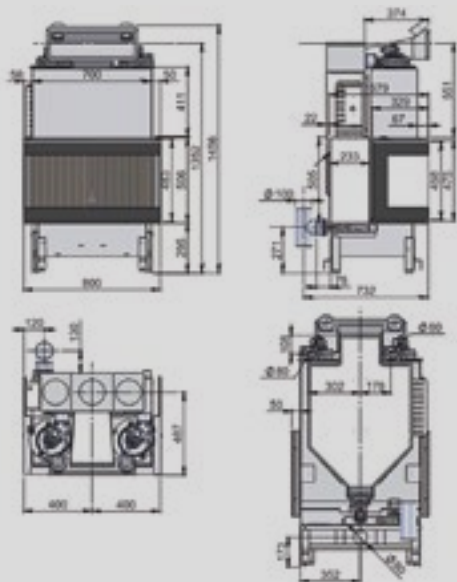

Insert en acier avec réservoir intégré et système d'alimentation. Vitre sérigraphiée et intérieur en vermiculite. Canalisé avec double brûleur. Sonde de température. Télécommande radio avec sonde de température intégrée. Clapet anti-surpression.

Steel pellet insert with an integrated tank and a feeding system. Screen printed glass, vermiculite combustion chamber. Channelled with a double burner. Remote control with temperature probe and anti over-pressure valve.

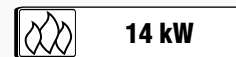

Rendement énergétique
(min / max) : 88.5 / 85

DIMENSIONS (mm)
DIMENSIONS

| L W | P D | H H |
|--------|--------|--------|
| 732 | 800 | 1450 |

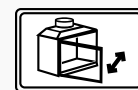
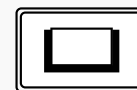

Classe énergétique : A+



FACEL 1000 EVO

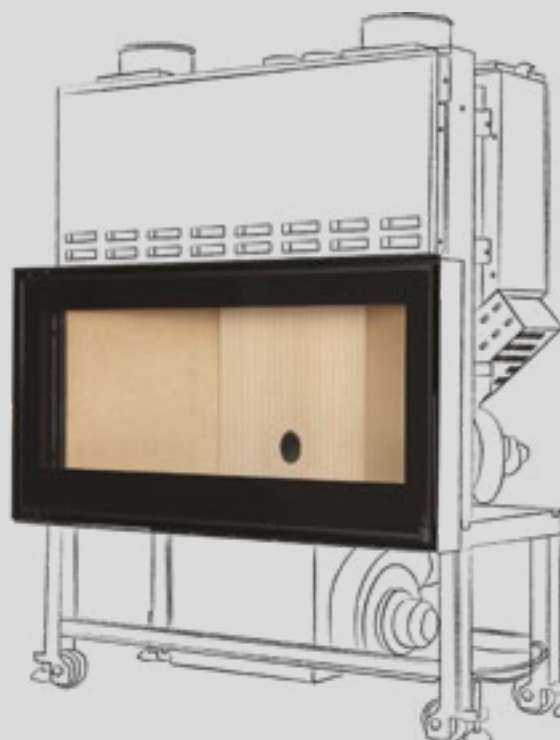
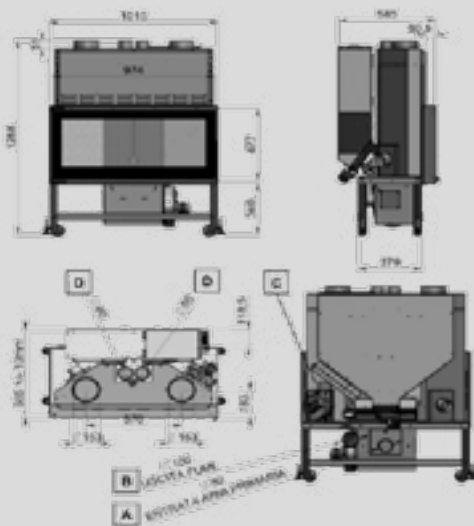

Insert en acier avec réservoir intégré et système d'alimentation. Vitre sérigraphiée 16/9 et intérieur en vermiculite. Canalisé avec double brûleur et sonde de température. Télécommande radio avec sonde de température intégrée. Clapet anti-surpression.

Steel pellet insert with an integrated tank and a feeding system. 16/9 screen printed glass, vermiculite combustion chamber. Channelled with a double burner. Remote control with temperature probe and anti over-pressure valve.

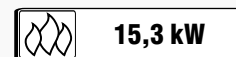

Rendement énergétique
(min / max) : 93.7 / 90.8

DIMENSIONS (mm)
DIMENSIONS

| L W | P D | H H |
|--------|--------|--------|
| 1010 | 585 | 1288 |

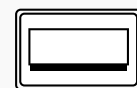

Classe énergétique : A+



ATMOS 70

Insert en acier avec réservoir intégré et système d'alimentation. Vitre sérigraphiée et intérieur en vermiculite. Creuset en fonte et une arrivée d'air. Sonde de température et télécommande radiographique
Steel pellet insert with an integrated tank and a feeding system. Screen printed glass, vermiculite combustion chamber. Cast-iron crucible and air inlet. Temperature probe and radio remote control.

Rendement énergétique
 (min / max) : 92.2 / 91.2

 **6,2 kW**



DIMENSIONS (mm)
 DIMENSIONS

| L W | P D | H H |
|--------|--------|--------|
| 687 | 576 | 470 |

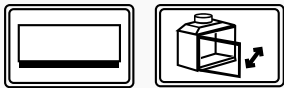

Classe énergétique : **A+**

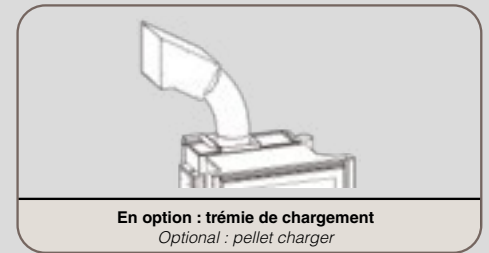
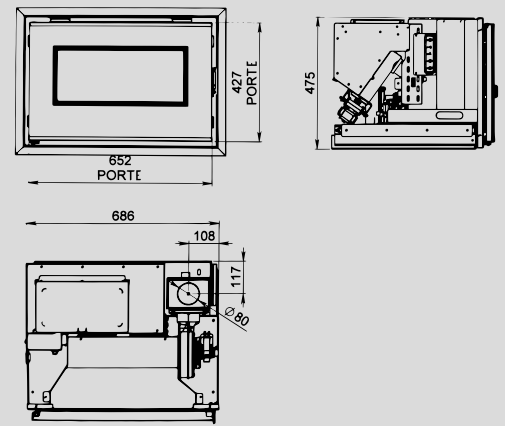

Options :

- Trémie de chargement (Pellet charger)
- Tiroir frontal de chargement (Front drawer to load)
- Raccordement air extérieur (Connection to outside air)

Insert en acier avec réservoir intégré et système d'alimentation. Vitre sérigraphiée 16/9 et intérieur en vermiculite. Creuset en fonte et une arrivée d'air. Sonde de température et télécommande Radiographique.
Steel pellet insert with an integrated tank and a feeding system. 16/9 Screen printed glass, vermiculite combustion chamber. Cast-iron crucible and air inlet. Temperature probe and radio remote control.

Rendement énergétique
 (min / max) : 94.4 / 92.7

 **9,8 kW**



DIMENSIONS (mm)
 DIMENSIONS

| L W | P D | H H |
|--------|--------|--------|
| 800 | 582 | 578 |



Classe énergétique : **A+**

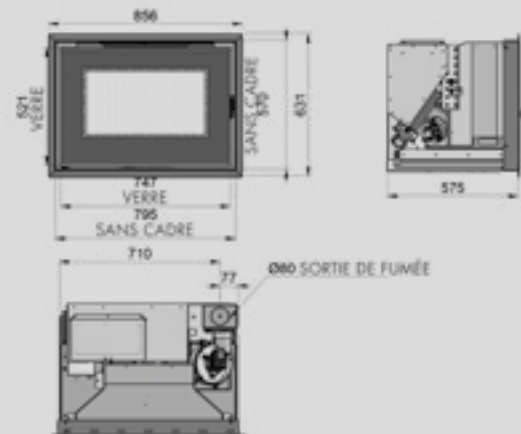

Options :

- Trémie de chargement (Pellet charger)
- Tiroir frontal de chargement (Front drawer to load)
- Canalisation d'air chaud (Hot air distribution)(channelled)
- Raccordement air extérieur (Connection to outside air)



BOIS

WOOD BURNING

HP 700

FONTE / CAST IRON

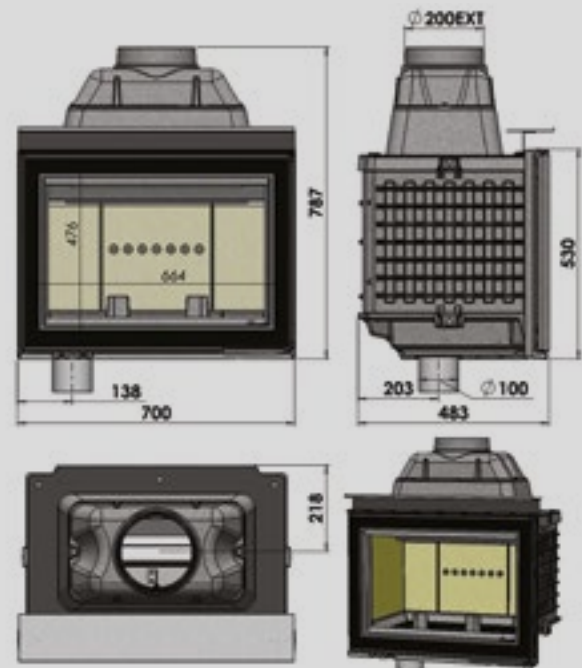

Post combustion

Options :

- Intérieur plaque acier / steel frame hearth
- Carénage / convection mantel

VINTAGE



Le HP 700 cumule confort d'utilisation, facilité d'entretien et fiabilité.
The HP 700 combines ease of use, simplicity of maintenance and reliability.

Dimensions / Dimensions

700 x 483 x 787 mm (L x P x H)

Combustible / Fuel



Puissance / Power

10 kW

Classe énergétique / Energy class

A

Rendement énergétique / Efficiency

78 %





HP 800

FONTE / CAST IRON

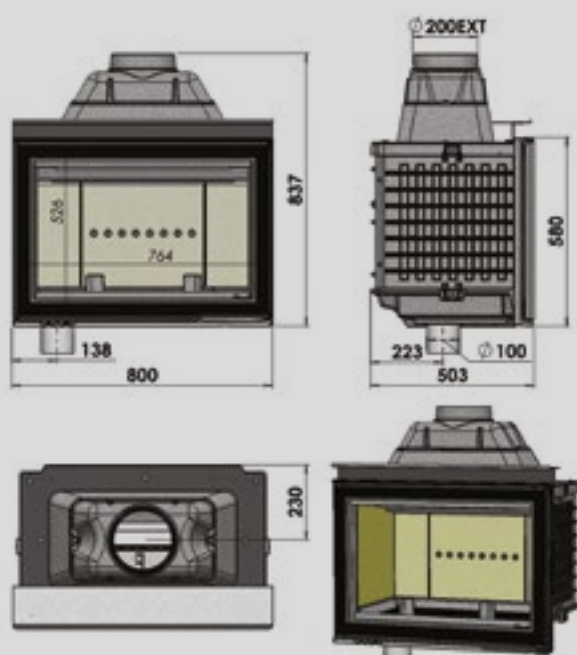

Post combustion

Options :

- Intérieur plaque acier / steel frame hearth
- Carénage / convection mantel

Son design aux lignes sobres et épurées est dessiné pour laisser toute latitude au regard sur les flammes.
Its design, with its sober and pure lines, is intended to allow the eye to focus on the flames.

Dimensions / Dimensions **870 x 570 x 840 mm (L x P x H)**

Combustible / Fuel



Puissance / Power

14 kW

Classe énergétique / Energy class

A

Rendement énergétique / Efficiency

77 %



BRILLAC



Insert acier avec vitre droite sérigraphiée. Composé de 2 commandes indépendantes pour le réglage de l'air primaire et secondaire.

Steel insert with straight screen printed glass. 2 independent controls for primary air and secondary regulation.

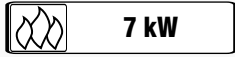

DIMENSIONS (mm)
DIMENSIONS

| L W | P D | H H |
|--------|--------|--------|
| 980 | 466 | 520 |

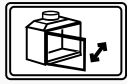
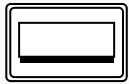

Rendement énergétique : 79%

Classe énergétique : A



VE 1000

ACIER / STEEL



Les intérieurs : 2 possibilités : briques beiges ou acier noir.
Inserts finishing: 2 choices: beige refractory bricks or black steel.

Options :
- Kit raccordement d'air extérieur avec pied.
Fresh air connecting kit with feet

*version métal



YOKO

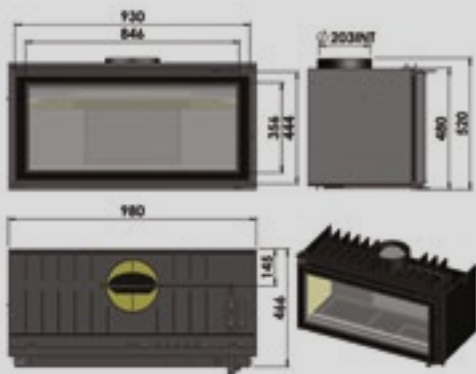

PRINCIPE DE FONCTIONNEMENT DE L'AIR DE CONVECTION ET FONCTIONNEMENT DE L'INSERT FONTE

OPERATING PRINCIPLE OF CONVECTION AIR FOR CAST IRON INSERT

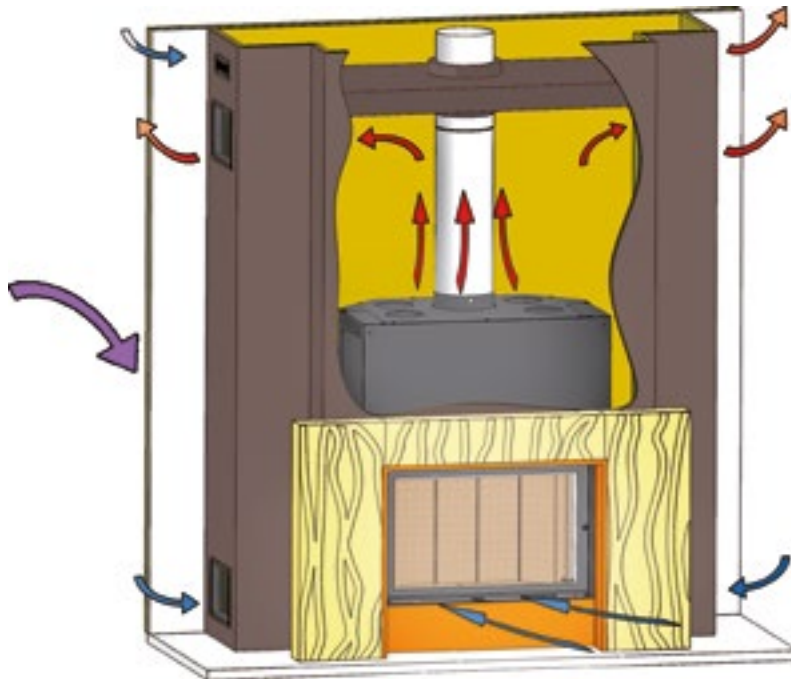

Section des entrées d'air de convection : 600 cm² mini
Inlet section of convection air : 600 cm² mini

S2 Section des sorties d'air de convection : 700 cm² mini
Outlet section of convection air : 700 cm² mini

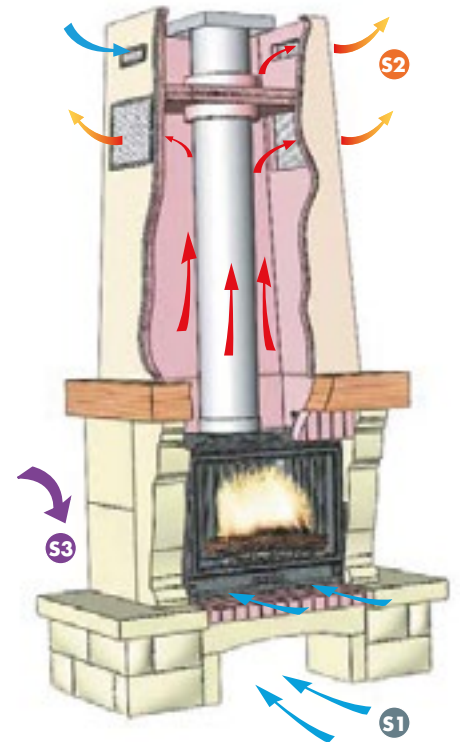

S3 Section de l'entrée d'air de combustion 200 cm² ou Ø 100 dans le cas d'un raccordement d'air extérieur
Inlet section of combustion air 200 cm² or Ø 100 mm in case of connection to outside air



Les inserts **NE** doivent **PAS** être isolés. Une lame d'air de 3 cm sur les côtés et 3 cm à l'arrière doit être laissée entre l'insert et l'isolation pour permettre à l'air de convection de prendre la chaleur de l'insert.

Inserts should **NOT** be isolated. A gap of minimum 3 cm on the sides and 3 to 5 cm at the back should be kept between the insert and the isolation board to let the convection air take the heat from the insert.

Courbe de fonctionnement d'un appareil à bois.
Curve on the functioning of a wood burning appliance.

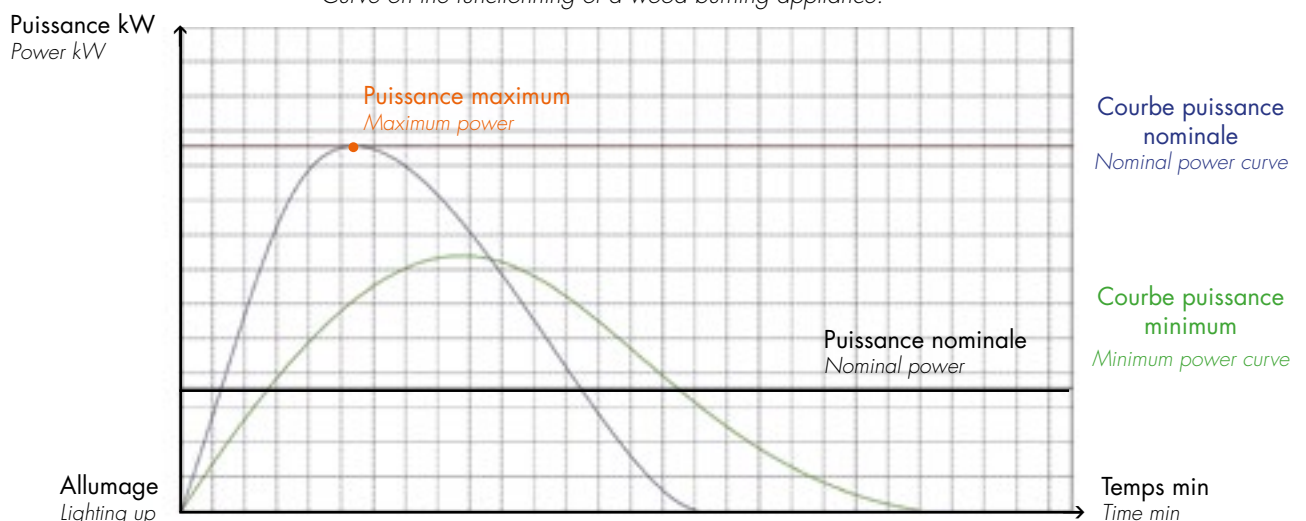

Insert acier avec vitre à droite ou à gauche sérigraphiée. Porte relevable pour le chargement du bois.

Intérieur briques réfractaires noires et système post combustion. Sole foyère en retrait et distribution d'air chaud interdite.

Steel insert with glass on the right or on the left. Lifting up door to refill with wood. Combustion chamber in black refractory bricks.



| DIMENSIONS (mm) DIMENSIONS | | |
|-------------------------------|--------|--------|
| L W | P D | H H |
| 724 | 483 | 1543 |

Option : Carénage / convection mantel

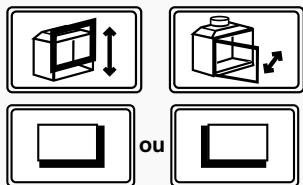

Rendement énergétique : 80%

Classe énergétique : A+

CLOUD 70R VAD

ACIER / STEEL



Poignée: Amovible
Handle : Removable

CLOUD 70R VAG

ACIER / STEEL



Poignée: Amovible
Handle : Removable

Insert acier avec vitre à droite ou à gauche sérigraphiée. Porte relevable pour le chargement du bois.

Intérieur briques réfractaires noires et système post combustion. Sole foyère en retrait et distribution d'air chaud interdite.

Steel insert with glass on the right or on the left. Lifting up door to refill with wood. Combustion chamber in black refractory bricks.

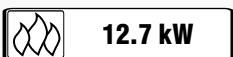

| DIMENSIONS (mm) DIMENSIONS | | |
|-------------------------------|--------|--------|
| L W | P D | H H |
| 947 | 483 | 161 |

Option : Carénage / convection mantel

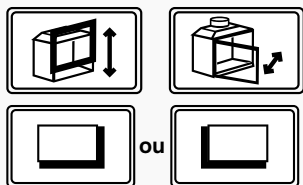

Rendement énergétique : 79%

Classe énergétique : A

CLOUD 90R VAD

ACIER / STEEL



CLOUD 90R VAG

ACIER / STEEL







CLOUD 70 3V

ACIER / STEEL

Insert acier avec 3 vitres sérigraphiées. Porte relevable pour le chargement du bois. Intérieur briques réfractaires noires et système post combustion. Sole foyère en retrait et distribution d'air chaud interdite.

3 sided steel insert. Lifting up door to refill with wood. Combustion chamber in black refractory bricks.

 **11 kW**



DIMENSIONS (mm)
DIMENSIONS

| L W | P D | H H |
|--------|--------|--------|
| 756 | 486 | 162 |

Option : Carénage / convection mantel

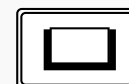
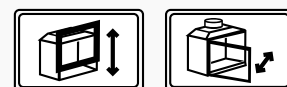

Rendement énergétique : 78%
Classe énergétique : **A**

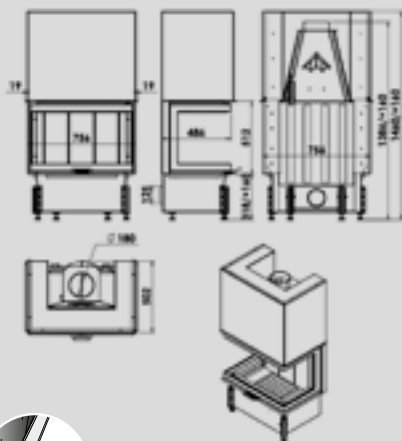

Poignée: Amovible
Handle : Removable



CLOUD 90 3V

ACIER / STEEL

Insert acier avec 3 vitres sérigraphiées. Porte relevable pour le chargement du bois. Intérieur briques réfractaires noires et système post combustion. Sole foyère en retrait et distribution d'air chaud interdite.

3 sided steel insert. Lifting up door to refill with wood. Combustion chamber in black refractory bricks.

 **11.9 kW**



DIMENSIONS (mm)
DIMENSIONS

| L W | P D | H H |
|--------|--------|--------|
| 922 | 523 | 162 |

Option : Carénage / convection mantel

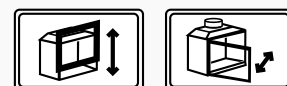

Rendement énergétique : 76.7%
Classe énergétique : **A**



Poignée: Amovible
Handle : Removable



Insert en acier avec vitre sérigraphiée et porte relevable pour le chargement du bois. Intérieur briques réfractaires noires et système post combustion. Sole foyère en retrait et distribution d'air chaud fortement déconseillée.

Frontal steel insert. Lifting up door to refill with wood. Combustion chamber in black refractory bricks.



12.1 kW



DIMENSIONS (mm)
DIMENSIONS

| L W | P D | H H |
|--------|--------|--------|
| 848 | 553 | 1844 |

Option : Carénage / convection
manteau

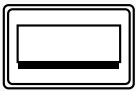
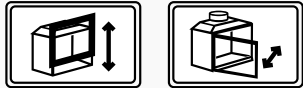

Rendement énergétique : 76.9%

Classe énergétique : **A**

CLOUD 80 R

ACIER / STEEL

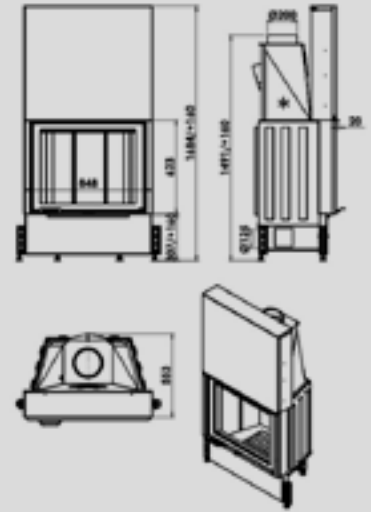

Poignée: Amovible
Handle : Removable

Insert en acier avec vitre sérigraphiée et porte relevable pour le chargement du bois. Intérieur briques réfractaires noires et système post combustion. Sole foyère en retrait et distribution d'air chaud fortement déconseillée.

Frontal steel insert. Lifting up door to refill with wood. Combustion chamber in black refractory bricks.



12 kW



DIMENSIONS (mm)
DIMENSIONS

| L W | P D | H H |
|--------|--------|--------|
| 970 | 546 | 1541 |

Option : Carénage / convection
manteau

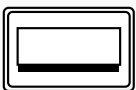
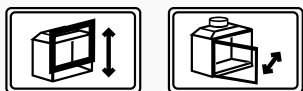

Rendement énergétique : 83%

Classe énergétique : **A+**

CLOUD 100 R

ACIER / STEEL

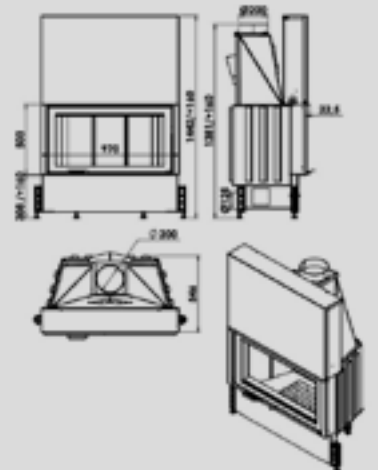

Poignée: Amovible
Handle : Removable





CLOUD 100 RDF

ACIER / STEEL

Insert en acier double face avec vitres sérigraphiées et porte relevable pour le chargement du bois. Porte latérale pour l'entretien et intérieur briques réfractaires noires. Système post combustion et sole foyer en retrait. Distribution d'air chaud interdite.

Double sided steel insert. Lifting up door to refill with wood. Combustion chamber in black refractory bricks.

 **12 kW**



DIMENSIONS (mm)
DIMENSIONS

| L W | P D | H H |
|--------|--------|--------|
| 964 | 581 | 1606 |

Option : Carénage / convection mantel

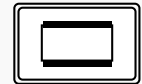
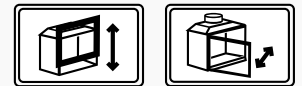

Rendement énergétique : 78%

Classe énergétique : **A+**

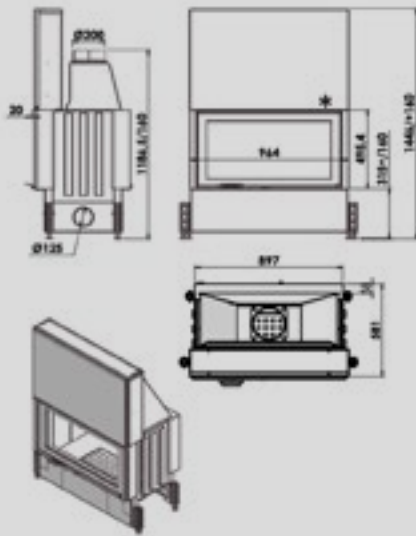

Poignée: Amovible
Handle : Removable

CLOUD 100 R HORIZON

ACIER / STEEL

Insert en acier avec vitre sérigraphiée et porte relevable pour le chargement du bois. Intérieur briques réfractaires noires et système post combustion. Sole foyer en retrait et distribution d'air chaud fortement déconseillée.

Frontal steel insert. Lifting up door to refill with wood. Combustion chamber in black refractory bricks.

 **13.2 kW**



DIMENSIONS (mm)
DIMENSIONS

| L W | P D | H H |
|--------|--------|--------|
| 107 | 563 | 1475 |

Option : Carénage / convection mantel

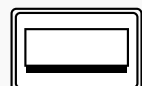
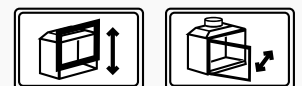

Rendement énergétique : 77.96%

Classe énergétique : **A**

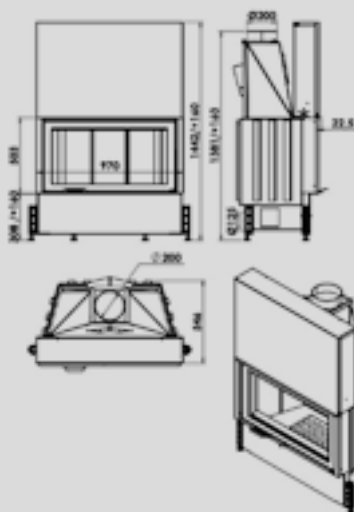

Poignée: Amovible
Handle : Removable

Insert en acier double face avec vitres sérigraphiées. Porte relevable pour le chargement du bois et porte latérale pour l'entretien. Intérieur briques réfractaires noires et système post combustion. Sole foyère en retrait et distribution d'air chaud interdite.

Double sided steel insert. Lifting up door to refill with wood. Combustion chamber in black refractory bricks.



12.5 kW



DIMENSIONS (mm)
DIMENSIONS

| L W | P D | H H |
|--------|--------|--------|
| 970 | 580 | 1350 |

Option : Carénage / convection mantel

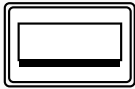
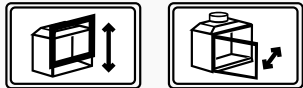

Rendement énergétique : 78.46%

Classe énergétique : **A**



Insert en acier double face avec vitres sérigraphiées. Porte relevable pour le chargement du bois et porte latérale pour l'entretien. Intérieur briques réfractaires noires et système post combustion. Sole foyère en retrait et distribution d'air chaud interdite.

Double sided steel insert. Lifting up door to refill with wood. Combustion chamber in black refractory bricks.



16.5 kW



DIMENSIONS (mm)
DIMENSIONS

| L W | P D | H H |
|--------|--------|--------|
| 1270 | 670 | 1350 |

Option : Carénage / convection mantel

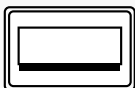

Rendement énergétique : 79.7%

Classe énergétique : **A**



CLOUD 100 RDF HORIZON

ACIER / STEEL

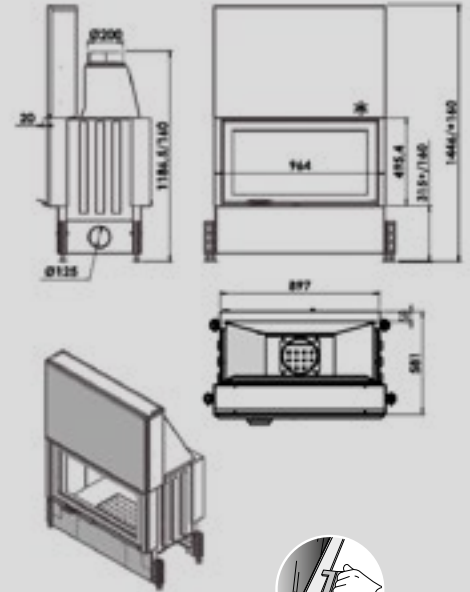

Poignée: Amovible
Handle : Removable

CLOUD 120 RDF HORIZON

ACIER / STEEL

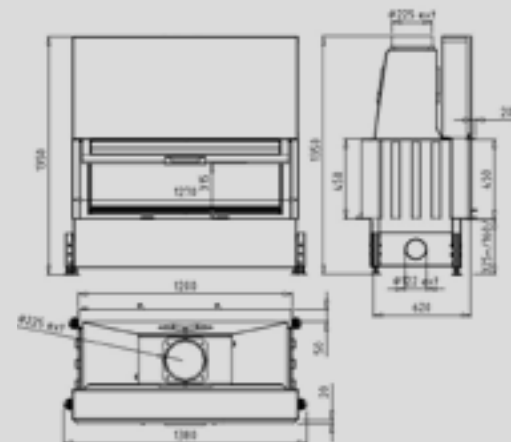

Poignée: Amovible
Handle : Removable





CLOUD 130 R

ACIER / STEEL

Insert en acier avec vitre sérigraphiée. Porte relevable pour le chargement du bois. Intérieur briques réfractaires noires et système post combustion. Sole foyère en retrait et distribution d'air chaud fortement déconseillée.

Frontal steel insert. Lifting up door to refill with wood. Combustion chamber in black refractory bricks.



 **16 kW**



DIMENSIONS (mm)
DIMENSIONS

| L W | P D | H H |
|--------|--------|--------|
| 1370 | 565 | 1470 |

Option : Carénage / convection
mantel

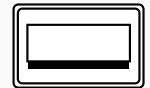
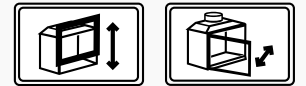

Rendement énergétique : 78%

Classe énergétique : **A**



Poignée: Amovible
Handle : Removable

CLOUD 150 R

ACIER / STEEL

Insert en acier avec vitre sérigraphiée. Porte relevable pour le chargement du bois. Intérieur briques réfractaires noires et système post combustion. Sole foyère en retrait et distribution d'air chaud fortement déconseillée.

Frontal steel insert. Lifting up door to refill with wood. Combustion chamber in black refractory bricks.

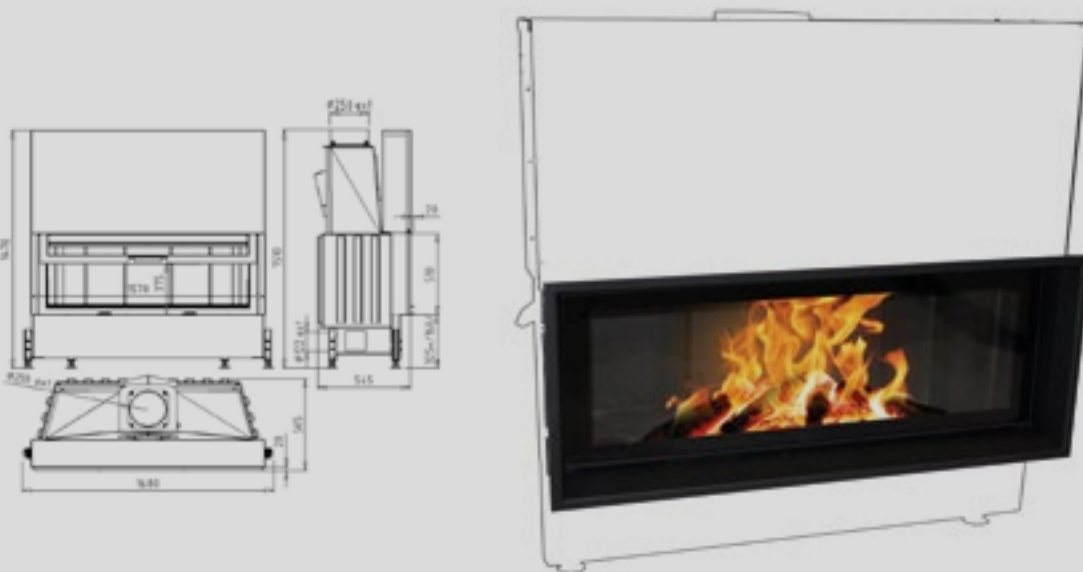

 **18.8 kW**



DIMENSIONS (mm)
DIMENSIONS

| L W | P D | H H |
|--------|--------|--------|
| 1570 | 565 | 1470 |

Option : Carénage / convection
mantel

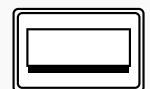
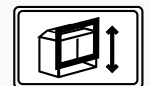

Rendement énergétique : 80.8%

Classe énergétique : **A+**



Poignée: Amovible
Handle : Removable

BOIS VENTILÉ

VENTILATED WOOD BURNING

VN 70

FONTE / CAST IRON



Une superbe vision panoramique du feu afin de vous permettre de profiter de moments inoubliables autour de belles flambées. Son système de ventilation permet de chauffer rapidement la pièce. Vous obtiendrez un rendement plus élevé et une moindre consommation de vos bûches.

A superb panoramic view of the fire to allow you to enjoy unforgettable moments around beautiful flame. Its ventilation system allows the room to be heated quickly. You will get a higher yield and less consumption of your logs.

Dimensions / Dimensions

778 x 535 x 585 mm (L x P x H)

Combustible / Fuel



Puissance / Power

8 kW

Classe énergétique/ Energy class

A

Rendement énergétique / Efficiency

77 %





VN 80

FONTE / CAST IRON



Cet insert à bûches présente un design moderne avec une grande façade en verre.

Il dispose d'une ventilation silencieuse, à trois vitesses, qui distribue efficacement la chaleur dans toute la pièce, et des sorties de canalisables pour conduire la chaleur vers les pièces annexes.

This wood burning insert has a modern design with a large glass front. It has silent, three-speed ventilation that efficiently distributes heat throughout the room, and ductable outlets to conduct heat to nearby rooms.

Dimensions / Dimensions

877 x 514 x 583 mm (L x P x H)

Combustible / Fuel



Puissance / Power

8 kW

Classe énergétique / Energy class

A

Rendement énergétique / Efficiency

79%



INSERTS 100% SUR-MESURE : DES PROJETS A L'INFINI

100% CUSTOM INSERTS

INSERT 1 FACE

Frontal insert

JUSQU'À 2M

up to 2m



INSERT 3 VITRES

3-sided insert

JUSQU'À 2M

up to 2m



Chazelles c'est aussi un savoir faire sur mesure et un accompagnement de A à Z dans la réalisation de vos projets.
Imaginé, personnalisé et adapté à votre intérieur comme vous l'aurait souhaité.

*Chazelles also provides a tailor-made expertise and support from A to Z in the realisation of your projects.
Imagine, personalise and adapt your interior as you would have loved to.*



INSERT VAG/VAD

Corner insert

JUSQU'À 2M
up to 2m



INSERT EPI

Room divider insert

JUSQU'À 2M
up to 2m



Insert en acier avec une finition contemporaine. Intérieur en fonte blanche.
Steel insert with a contemporary finish. Combustion chamber in white cast iron.

Steel insert with a contemporary finish. Combustion chamber in white cast iron.



Longueur de bûche : 40 cm
Log length : 40 cm



| DIMENSIONS (mm) | | |
|-----------------|--------|--------|
| DIMENSIONS | | |
| L W | P D | H H |
| 584 | 450 | 644 |

Option : Télécommande / remote control

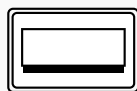

Rendement énergétique : 71.1%
Classe énergétique : A

IQ 33

ACIER

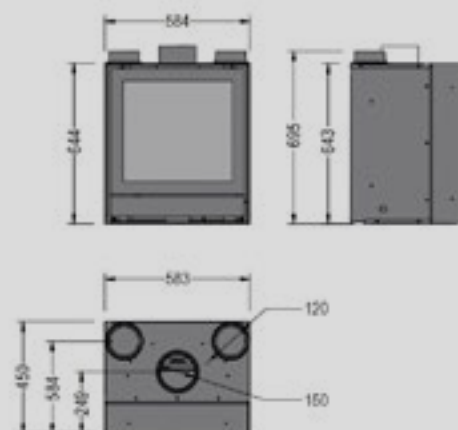

Option : Cadre 50 mm
Option : Frame 50 mm

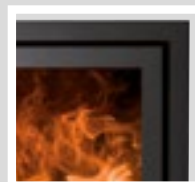

Insert acier avec une finition contemporaine. Intérieur en fonte blanche.
Steel insert with a contemporary finish. Combustion chamber in white cast iron.

Steel insert with a contemporary finish. Combustion chamber in white cast iron.

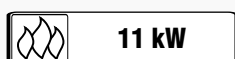

Longueur de bûche : 55 cm
Log length : 55 cm



| DIMENSIONS (mm) | | |
|-----------------|--------|--------|
| DIMENSIONS | | |
| L W | P D | H H |
| 692 | 498 | 666 |

Option : Télécommande / remote control

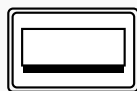

Rendement énergétique : 71.2%
Classe énergétique : A

IQ 43

ACIER



WOODBBOX® TECHNOLOGY

Permet de combiner la **jouissance de la chaleur** et la **simplicité d'utilisation** avec une **performance exceptionnelle de combustion**.

Combines the enjoyment of warmth and simplicity of use with exceptional combustion performance.

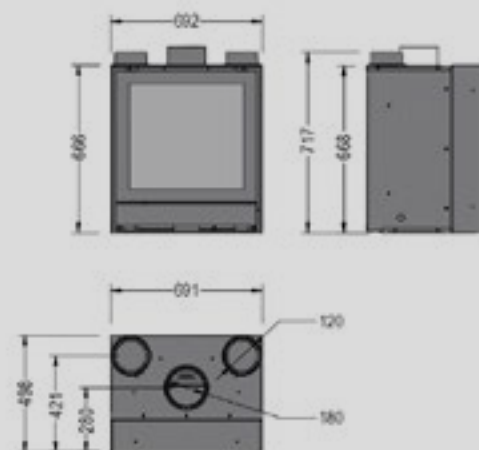

Option : Cadre 50 mm
Option : Frame 50 mm

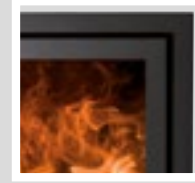

IQH 33

ACIER

Insert acier avec une finition contemporaine. Intérieur en fonte blanche.
Steel insert with a contemporary finish. Combustion chamber in white cast iron.

Steel insert with a contemporary finish. Combustion chamber in white cast iron.

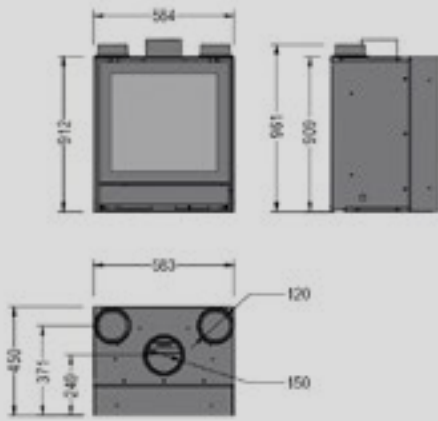

Option : Cadre 50 mm
Option : Frame 50 mm

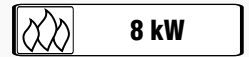

8 kW



Longueur de bûche : 40 cm
Log length : 40 cm

DIMENSIONS (mm)
DIMENSIONS

| L W | P D | H H |
|--------|--------|--------|
| 584 | 450 | 912 |

Option : Télécommande / remote control

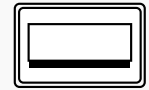
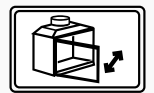
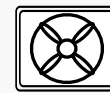

Rendement énergétique : 81.4%
Classe énergétique : A+



OPTION :
Télécommande thermostatique /
Thermostatic remote control

IQH 43

ACIER

Insert acier avec une finition contemporaine. Intérieur en fonte blanche.
Steel insert with a contemporary finish. Combustion chamber in white cast iron.

Steel insert with a contemporary finish. Combustion chamber in white cast iron.

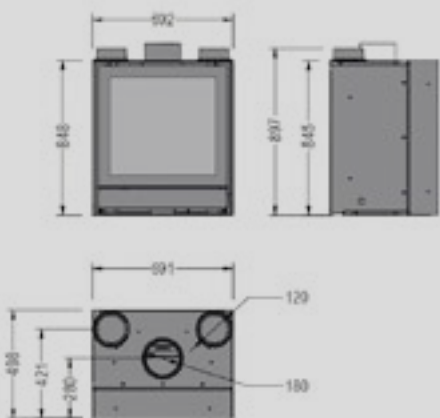

Option : Cadre 50 mm
Option : Frame 50 mm



14.7 kW



Longueur de bûche : 50 cm
Log length : 50 cm

DIMENSIONS (mm)
DIMENSIONS

| L W | P D | H H |
|--------|--------|--------|
| 692 | 498 | 848 |

Option : Télécommande / remote control

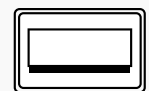
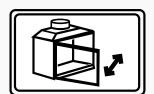
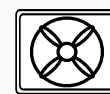

Rendement énergétique : 77.3%
Classe énergétique : A



HYDRO

HYDRO

FACEL 1000 HYDRO

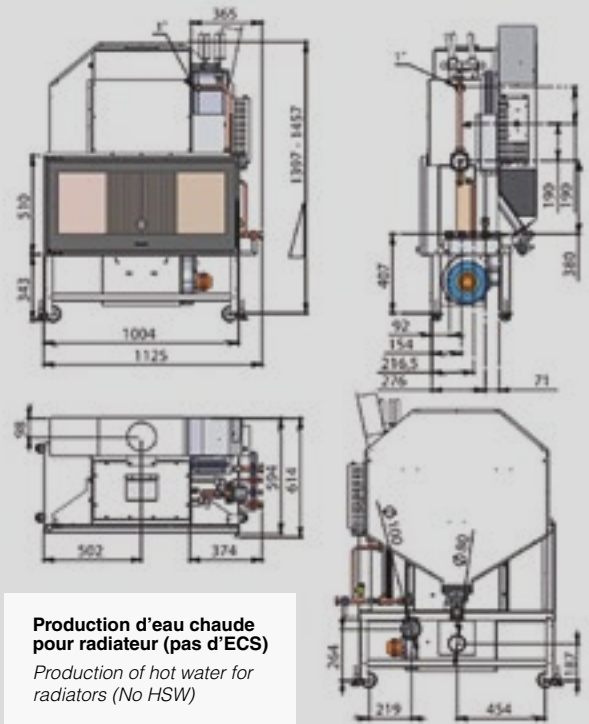
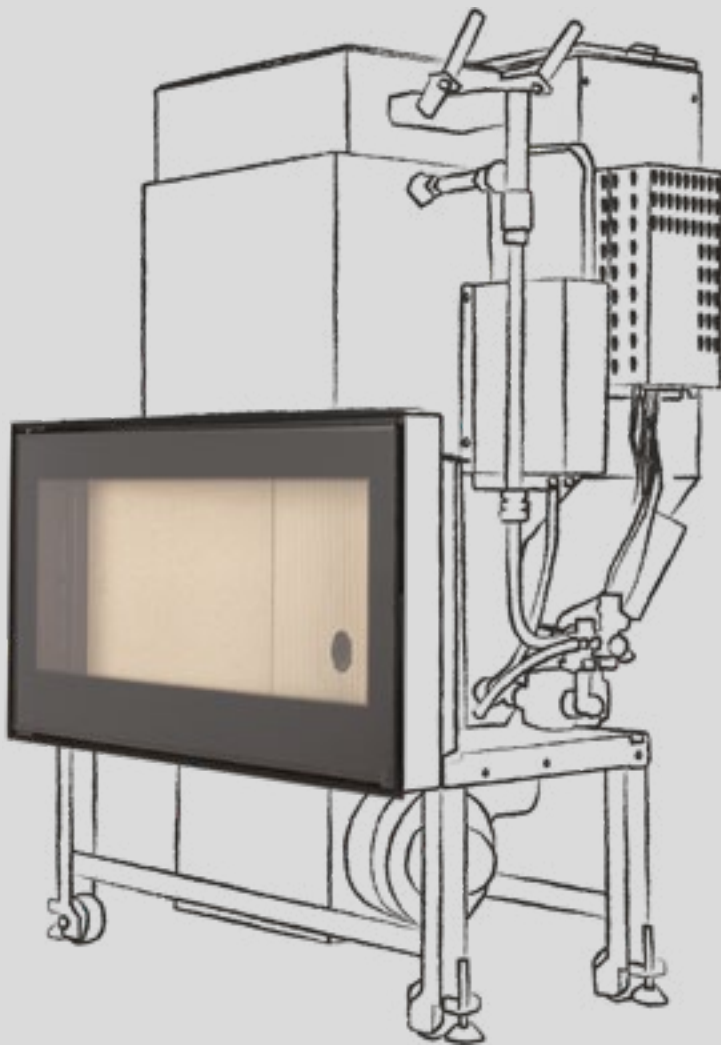

Insert en acier, réserve intégrée, système d'alimentation avec double brûleur et sonde de température. Vitre Sérigraphiée et intérieur en vermiculite. Possède une télécommande radiographique et un clapet anti-surpression.

Steel insert, integrated tank, feeding system with a double burner and a temperature probe. Screen printed glass and vermiculite combustion chamber. Radio remote control and anti-over-pressure valve.

Dimensions / Dimensions

1125 x 614 x 1460 mm (L x P x H)

Combustible / Fuel



Puissance / Power

31.5 kW

Classe énergétique / Energy class

A+





CLOUD 80R HYDRO

Insert hydro en acier. Porte relevable pour le bois. Chambre de combustion en briques réfractaires.

Hydro steel insert. Lifting up door to refill with wood. Combustion chamber in black refractory bricks.

 **14,5 kW**



Longueur de bûche : 50 cm
Log length : 50 cm

DIMENSIONS (mm)
DIMENSIONS

| L W | P D | H H |
|--------|--------|--------|
| 848 | 608 | 1574 |

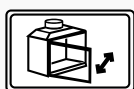
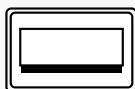

Classe énergétique : **A+**

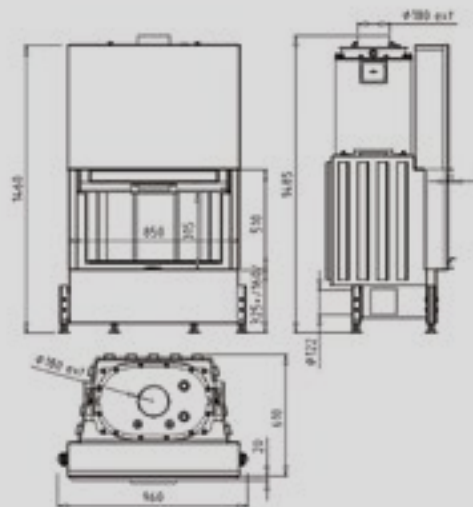

Poignée: Amovible
Handle : Removable





DISTRICHAUFF : DISTRIBUTION D'AIR CHAUD

Hot air distribution

PROFITEZ DU CHAUFFAGE AU BOIS DANS TOUTE VOTRE MAISON.

enjoy wood burning in your house.

DISTRICHAUFF est un système permettant de distribuer la chaleur dans toutes les pièces de votre maison. Grâce à votre cheminée et son insert profitez d'une température ambiante sans augmenter votre consommation de combustible.

DISTRICHAUFF is a system for distributing heat in all the rooms of your house. Thanks to your fireplace and his insert, enjoy an ambient temperature without increasing your fuel consumption.

L'installation DISTRICHAUFF est composée d'un caisson de distribution de gaines isolées et de bouches de soufflage. En récupérant la chaleur produite par votre appareil, elle va pouvoir la redistribuer de façon homogène dans les pièces de votre foyer.

The DISTRICHAUFF installation is made up of a distribution box, insulated ducts and air outlets. By recovering the heat produced by your appliance, it will be able to redistribute it homogeneously in the rooms of your home.

Le système **DISTRICHAUFF** est équipé d'un BYPASS* qui limite la mise en dépression de la hotte ou du carénage et améliore considérablement le confort thermique.

The DISTRICHAUFF system is equipped with a BYPASS which limits the depression of the hood and shroud, and improves thermal comfort.*

❗ Une distribution d'air chaud ne peut être installée qu'avec un insert Chazelles utilisant le bois comme combustible (compatible avec tous les inserts Chazelles, excepté les inserts double face, vitres à droite ou à gauche, 3 vitres ou EPI).

❗ A hot air distribution must be installed with Chazelles insert using wood as fuel (compatible with all inserts Chazelles, except the double-sided, windows to the right or left, 3 sided or EPI inserts).





Le système est composé :

The system is composed :

- 1** : Cheminée / fireplace
- 2** : Insert / insert
- 3** : Groupe de ventilation avec by-pass / ventilation box with by-pass
- 4** : Caisson de répartition / distribution box
- 5** : Gains d'air chaud isolées thermiquement & phoniquement / thermally and acoustically insulated ducts for hot air
- 6** : Bouches de soufflage / air outlets
- 7** : Bouche de reprise pour BYPASS* / air inlet fo BYPASS*

3 : Groupe de ventilation avec by-pass / ventilation box with by-pass



3 versions available / 3 versions disponibles

- Districhauff 200 m³/h By pass
- Districhauff 300 m³/h By pass
- Districhauff 500 m³/h By pass

4 : Caisson de répartition / distribution box



5 : Gains d'air chaud isolées thermique phonique / thermal and acoustical insulated ducts for hot air

6 : Bouches de soufflage / Air outlets



Bouche
Outlet



Manchon
Sleeve

7 : Bouche de reprise pour BYPASS* / air inlet for BYPASS*



Bouche
Inlet



Manchon
Sleeve

GAZ

GAS

1 VITRE

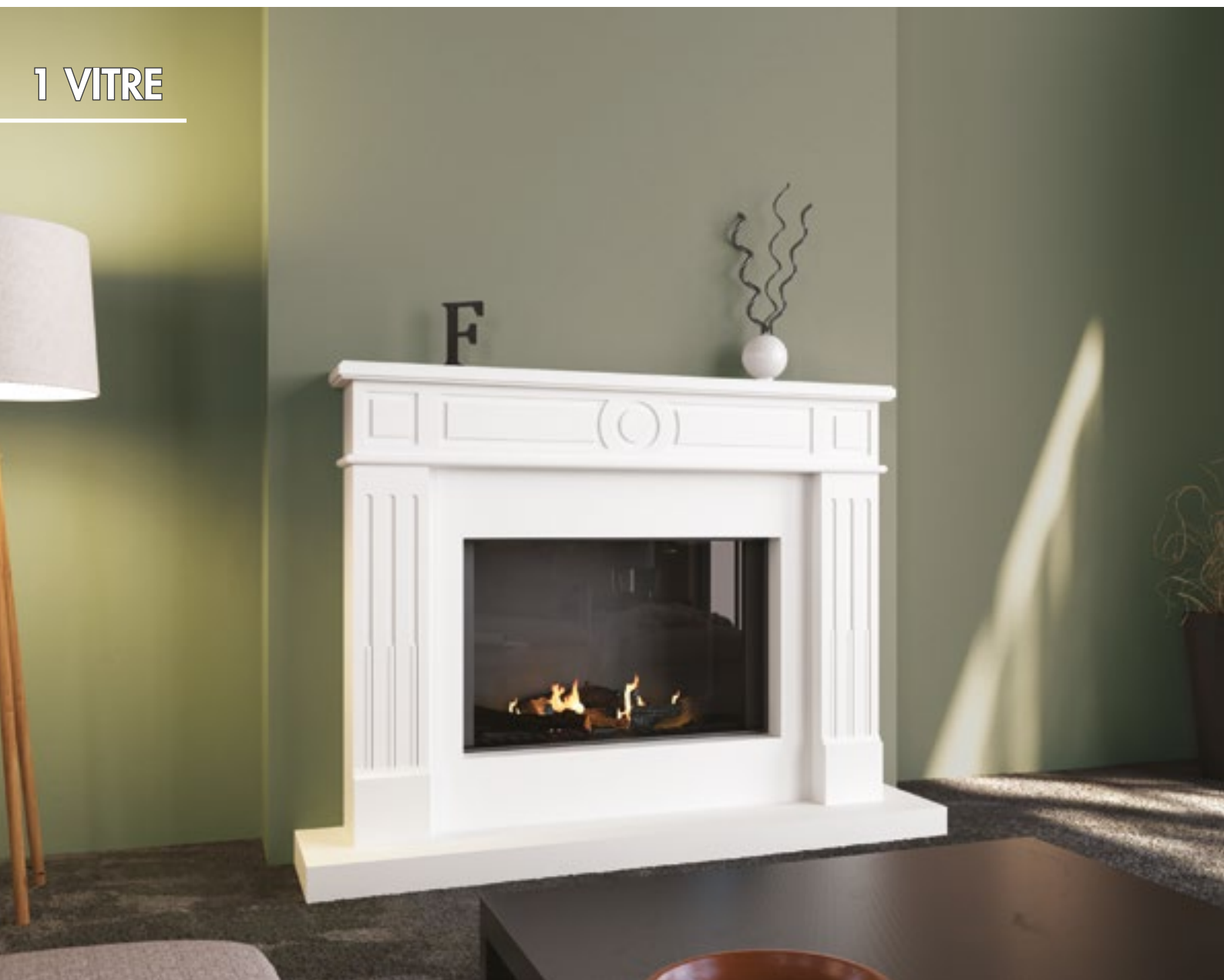

Insert gaz en acier équipé de la technologie Mertik, télécommande avec sonde intégrée, application smartphone, effet combustion réaliste grâce à 3 brûleurs, 2 versions de décoration intérieures : buches céramiques ou pierres blanches. 3 modes de fonctionnement : thermostatique, programmation ou éco.

Steel gas insert equipped with Mertik technology, remote control with integrated probe, smartphone application, realistic combustion effect thanks to 3 burners, 2 interior decoration versions: ceramic logs or white stones. 3 operating modes: thermostatic, programming or eco.

| Modèles <i>Models</i> | kW (naturel) | kW (propane) | Dimensions vitres <i>Glass dimensions</i> (L x H) | Classe énergétique <i>Energy class</i> |
|--------------------------|-----------------|-----------------|---|---|
| 70 | 12 | 11.8 | 650 X 448 x 266 mm | A+ |
| 80 | 12 | 11.8 | 750 x 448 x 266 mm | A+ |
| 100 | 14 | 17 | 950 x 448 mm | A+ |
| 150 | 17.5 | 17 | 1450 x 448 mm | A+ |
| 200 | 22.5 | 21 | 1961 x 448 x 400 mm | A+ |





VAD/ VAG

Insert gaz se fond parfaitement dans un intérieur moderne ou plus classique en apportant une touche de chaleur. Ses trois brûleurs à la pointe de la technologie vous apportent une sensation de chaleur agréable et surtout contrôlable.

Gas insert blends perfectly into a modern or more classic interior bringing a touch of warmth. Its three state-of-the-art burners give you a pleasant and especially controllable feeling of warmth.

| Modèles Models | kW (naturel) | kW (propane) | Dimensions vitres Glass dimensions (L x H) | Classe énergétique Energy class |
|-------------------|-----------------|-----------------|--|------------------------------------|
| 70 | 12 | 11.8 | 678 x 448 x 266 mm | A+ |
| 80 | 12 | 11.8 | 778 x 448 x 266 | A+ |
| 100 | 14 | 17 | 978 x 448 x 266 mm | A+ |
| 150 | 17.5 | 17 | 1478 x 448 x 266 | A+ |



SWEETLINE 3 vitres

Ses 3 faces vitrées, laissent paraître de belles flammes grâce à ses trois brûleurs dotés d'une technologie de pointe. Parfait pour habiller un mur et donner un aspect chaleureux, cet insert est fait pour les personnes à la recherche de confort et de simplicité.

Its three-glass-sided shape shows beautiful flames thanks to its three burners equipped with the latest technology. This insert is ideal to dress up a wall and add a warm aspect, it is intended for people seeking comfort and simplicity.



3 VITRES

Garanti 5 ans, le Sweetline 150 3 V possède une puissance de 17,5 kW et un rendement de 84%. Dominez les flammes et faites opérer la magie instantanément grâce à cet appareil de chauffage au gaz à 3 faces vitrées.

Warranty for 5 years, the Sweetline 150 3 V has a power of 17,5 kW and an efficiency of 84%. Overcome the flames and let the magic happen instantly with this 3-sided glass gas heater.

| Modèles Models | kW (naturel) | kW (propane) | Dimensions vitres Glass dimensions (L x H) | Classe énergétique Energy class |
|-------------------|-----------------|-----------------|--|------------------------------------|
| 70 | 12 | 11.8 | 699 x 448 x 266 | A+ |
| 80 | 12 | 11.8 | 799 x 448 x 266 | A+ |
| 100 | 14 | 17 | 999 x 448 x 266 mm | A+ |
| 150 | 17.5 | 17 | 1499 x 448 x 266 | A+ |

SWEETLINE EPI

La pureté et la finesse se trouvent dans cet insert sur-mesure Chazelles, qui sait parfaitement allier esthétique et performance apportant une touche chaudement originale. Sa forme et ses trois brûleurs de haute technologie vous feront profiter d'un feu sublime à travers ses longues vitres.

Purity and finesse are to be found in this chazelles insert, which perfectly combines design and performance, providing a warmly original accent. With its shape and its three high-tech burners, you will benefit from a sublime fire through its long panes.



Garanti 5 ans, le Sweetline 100 EPI possède un rendement de 84% et une puissance de 14 kW. Cet insert Chazelles, qui sait parfaitement allier esthétique et performance apportant une touche chaudement originale.

Warranty for 5 years, the Sweetline 100 EPI has a power of 14 kW and an efficiency of 84%. Overcome the flames and let the magic happen instantly with this room divider gas insert.

| Modèles Models | kW (naturel) | kW (propane) | Dimensions vitres Glass dimensions (L x H) | Classe énergétique Energy class |
|-------------------|-----------------|-----------------|--|------------------------------------|
| 100 | 14 | 17 | 985 x 448 x 303 mm | A+ |
| 200 | 22.5 | 21 | (1985 + 303) x 448 mm | A+ |



SWEETLINE double faces

Un insert double face est l'appareil idéal pour créer une séparation moderne et esthétique entre deux pièces. Cela permet de profiter du spectacle des flammes des deux côtés avec un réalisme exceptionnel.

A double-sided insert is the ideal device to create a modern and aesthetic separation between two areas. It allows you to enjoy the spectacle of the flames on both sides with an exceptional realism.

DOUBLE FACES



Garanti 5 ans, cet appareil offre une puissance de 22,5 kW et un rendement de 84%. Le Sweetline DF peut être utilisé pour séparer deux pièces grâce à sa vitre double faces, qui permet au feu d'être visible de devant comme de derrière

With a 5 year warranty, this device offers a power of 22,5 kW and an efficiency of 84%. The Sweetline DF can be used to separate two rooms thanks to its double-sided glass ; which allows the fire to be visible from the front as well as from back.

| Modèles Models | kW (naturel) | kW (propane) | Dimensions vitres Glass dimensions (L x H) | Classe énergétique Energy class |
|-------------------|-----------------|-----------------|--|------------------------------------|
| 100 | 14 | 17 | 961 x 448 mm | A+ |
| 200 | 22..5 | 21 | 1961 x 448 x 400 | A+ |

SWEETLINE, LE GOÛT DU SUR MESURE

Notre Gamme **SWEETLINE** s'adapte à tous vos désirs...

Ces Inserts disposent d'un large choix de personnalisation de parois, de sole foyères et de vitres.

Ils sont également équipés de 3 brûleurs permettant de faire varier les hauteurs et l'intensité des flammes en fonction de votre humeur ou de vos envies.

SWEETLINE, THE TASTE OF WARMTH

Our sweetline range adapts to all your wishes. these inserts have a wide choice of customised walls, hearths and panes.

They are also equipped with 3 burners which enables to choose flame heights and intensity according to your mood or desire.

SWEETLINE, EFFET DE COMBUSTION REALISTE

Tous les modèles, quelle que soit leur taille, ont un « effet de combustion réaliste ». Ce système vous permettra de donner véritablement l'impression que les flammes sortent des bûches, elle redonnera à votre intérieur l'esprit traditionnel des feux de bois.



SWEETLINE, REALISTIC BURNING EFFECT

All models, regardless of size, have a «realistic burning effect». This system allows you to give the impression that the flames are truly coming out of the logs, and it will give your home the traditional spirit of a wood fire.



SWEETLINE, L'APPLICATION



La nouvelle application myfire© vous permet par une simple action de tourner, frôler, glisser ou toucher pour décider de votre confort et un contrôle absolu de votre insert gaz.

SWEETLINE, THE APPLICATION



The new myfire© app allows you to decide on your comfort and to fully control your gas with a simple action, turn, swipe or slide.

LES VERSIONS / VERSIONS

REVÊTEMENT DU SOL / FLOORING



PIERRES BLANCHES
WHITE STONES

REVÊTEMENT DU SOL / FLOORING



BÛCHES CÉRAMIQUES + FILAMENTS
INCANDESCENTES
CERAMIC LOGS + INCANDESCENT
FILAMENTS OR WHITE STONES

SUR TOUS LES MODÈLES / ON ALL APPLIANCES

REVÊTEMENT INTÉRIEUR DES PAROIS INTERNAL WALL LINING



PAROI EN ACIER NOIR
BLACK STEEL

COMMANDE / CONTROL



TÉLÉCOMMANDE
REMOTE CONTROL

LES OPTIONS / OPTIONS

L'APPLICATION / MOBILE APPLICATION



MYFIRE©





LES POÊLES

STOVES

Granulés - Bois
Pellet - Wood

GRANULÉS

PELLET



LE WIFI SUR NOS POÊLES



Nos poêles à granulés sont composés d'une carte électronique qui peut se commander à distance à l'aide du réseau WIFI. Vous pouvez, de ce fait, allumer, éteindre, réguler et même programmer votre poêle où que vous soyez et à tout moment grâce à notre application !

Facilité d'utilisation et rapidité d'exécution, connecter votre poêle au WIFI vous simplifiera la vie.

*Our pellet stoves are equipped with an electronic board which can be controlled remotely using the WIFI network. You can therefore switch on, switch off, regulate and even program your stove wherever you are at any time thanks to our application!
Easy to use and fast, connecting your stove to WIFI will simplify your life.*

ICONIC O



Poêle avec structure en acier.
Steel stove

ICONIC O :

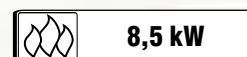

DIMENSIONS (mm)
DIMENSIONS

| L <i>W</i> | P <i>D</i> | H <i>H</i> |
|---------------|---------------|---------------|
| 544 | 559 | 1210 |

Couleurs disponibles



Blanc
White



Noir
Black

Capacité réservoir : 17 kg

Rendement énergétique
(min / max) : 94.2 / 91.9

Classe énergétique : **A++**



ICONIC S

Laissez-vous impressionner par la plus belle flamme du marché. Contemplez le feu avec l'effet d'un poêle à bois. Sélectionnez la température souhaitée, votre poêle s'occupe du reste grâce à sa régulation de la température ambiante automatique.

Let yourself be impressed by the most beautiful flame on the market. Contemplate the fire with the effect of a wood stove. Select the desired temperature, your stove takes care of the rest thanks to its automatic room temperature control.



Poêle avec structure en acier.
Steel stove

Étanche 50 PA

Couleurs disponibles



Blanc
White

Noir
Black

Dimensions / Dimensions

958 x 410 x 1206 mm (L x P x H)

Combustible



Puissance

8,5 kW

Classe énergétique

A++

Rendements énergétique (minimale / maximale)

95.3 / 94

Capacité du réservoir (en kg)

40



ICONIC C

Le plaisir d'une chaleur agréable et d'une flamme saisissante avec un effet de feu de bois. Un poêle haut de gamme avec un système de régulation automatique de la température ambiante, pilotable à distance pour un meilleur confort.

The pleasure of pleasant warmth and a striking flame with a wood-burning effect. A top-of-the-range stove with an automatic room temperature control system, which can be controlled remotely for better comfort.



Poêle avec structure en acier.
Steel stove

Etanche 50 PA

Couleurs disponibles



Blanc
White

Noir
Black

Dimensions / Dimensions

565 x 643 x 1196 mm (L x P x H)

Combustible



Puissance

8,5 kW

Classe énergétique

A++

Rendements énergétique (minimale / maximale)

92.5 / 90.4

Capacité du réservoir (en kg)

32



SAPHIR

Le poêle à granulés Saphir 9 offre un design épuré et contemporain grâce à sa structure en acier, de couleur grise ou noire, encadrant une très élégante vitre sérigraphiée noire.

The pellet stove Saphir 9 offers a clean and contemporary design thanks to its steel structure, grey or black, framing a very elegant black screen-printed glass.



SAPHIR

Sortie
supérieure

Poêle avec structure en acier.
Steel stove

Étanche 50 PA

Couleurs disponibles



Gris
Grey



Noir
Black

En option



Bleu texturé
Textured blue



Vert texturé
Textured green

SAPHIR 6

Dimensions cadre / Frame Dimensions **558 x 518 x 1123 mm (L x P x H)**

Combustible 

Puissance **6 kW**

Classe énergétique **A+**

Rendement énergétique (minimale / maximum) **94.3 / 93.3**

Capacité du réservoir (en kg) **19**

SAPHIR 9

Dimensions cadre / Frame Dimensions **558 x 518 x 1123 mm (L x P x H)**

Combustible 

Puissance **9 kW**

Classe énergétique **A+**

Rendement énergétique (minimale / maximum) **94.3 / 91.8**

E-KULT UP

Il se présente comme le must-have des poêles. Appareil design, économique et pratique, il est aussi déclinable en 4 coloris. Ce poêle moderne et performant sera vous satisfaire sur tous les angles.

It is the must-have of stoves. It is a design device, economical and practical, it is also available in 4 colours. This modern and efficient stove will satisfy you on all aspects.



Poêle avec structure en acier au design avant gardiste.

Steel stove.

Étanche 50 PA

Couleurs disponibles



Noir
Black

En option



Bleu texturé
Textured blue



Vert texturé
Textured green

Dimensions / Dimensions

558 x 500 x 1113 mm (L x P x H)

Combustible



Puissance

9 kW

Classe énergétique

A+

Rendements énergétique (minimale / maximale)

94 / 91.8

Capacité du réservoir (en kg)

16



ELANCE EVO

Poêle à granulés de dernière génération (compatible au WIFI*), Elance EVO associe design et haut rendement énergétique. Issu du savoir-faire technique Chazelles, Elance EVO est une invitation au confort au sens large.

*Latest generation pellet stove (WIFI * compatible), Elance EVO combines design and high energy efficiency. Thanks to Chazelles technical experience, Elance EVO is an invitation to comfort.*

ELANCE EVO



Couleurs disponibles en option



Poêle avec structure en acier.
Stove with steel structure.

Etanche 50 PA

Couleurs disponibles



| | |
|--|---------------------------------|
| Dimensions / Dimensions | 574 x 541 x 1131 mm (L x P x H) |
| Combustible | |
| Puissance | 8 kW |
| Classe énergétique | A+ |
| Rendements énergétique (minimale / maximale) | 93 / 90 |
| Capacité du réservoir (en kg) | 22 |
| Option | Canalisé |

ELANCE GLASS

Poêle en acier avec une grande vitre en façade.
Stove with steel structure.



8 kW



DIMENSIONS (mm)
DIMENSIONS

| L W | P D | H H |
|--------|--------|--------|
| 574 | 541 | 1131 |

Rendement énergétique : 93 %
Capacité du réservoir : 22 kg
Classe énergétique : A

Étanche 50 PA

Couleurs disponibles



Blanc
White



Noir
Black



Canalisé : En option

ELANCE FULL GLASS

Poêle en acier tout vitré
Stove with steel structure.



8 kW



DIMENSIONS (mm)
DIMENSIONS

| L W | P D | H H |
|--------|--------|--------|
| 574 | 541 | 1131 |

Rendement énergétique : 93 %
Capacité du réservoir : 22 kg
Classe énergétique : A



Étanche 50 PA

Couleurs disponibles



Noir
Black



Canalisé : En option

T-BARBARA II

Élégance et discrétion sont les atouts « style » de ce poêle à granulés en acier blanc, aux angles ronds et à l'encadrement noir. Avec ses 11 coloris en option, il s'adaptera à tous les goûts et trouvera facilement sa place dans les différents styles d'intérieurs.

Elegance and discretion are the «style» assets of this white steel pellet stove, with round corners and a black frame., with round angles and black frame. With its 11 optional colours, it will adapt to all tastes and easily find its place in different interior designs. The Barbara II diffuses a soft and natural heat.

T-BARBARA II 10 & 12 C



Couleurs disponibles en option



Bleu texturé
Textured blue



Vert texturé
Textured green



Orange texturé
Textured orange



Taupe texturé
Textured mole



Blanc texturé
Textured white



Gris anthracite
Charcoal grey



Gris clair texturé
Light grey



Rouge texturé
Textured red



Noir texturé
Textured black

Poêle avec structure en acier.
Steel stove

Étanche 50 PA

Couleurs disponibles



Blanc
White



Rouille
Rust

T-BARBARA II 10

Dimensions cadre / Frame Dimensions **530 x 540 x 1090 mm (L x P x H)**

Combustible

Puissance **10 kW**

Classe énergétique **A+**

Rendement énergétique (minimale / maximum) **97.5 / 90**

Capacité du réservoir (en kg) **20**

T-BARBARA II 12 CANALISÉ

Dimensions cadre / Frame Dimensions **530 x 540 x 1090 mm (L x P x H)**

Combustible

Puissance **12 kW**

Classe énergétique **A+**

Rendement énergétique (minimale / maximum) **95 / 88.5**

OLZONE

Le poêle à granulés Olzone est très silencieux grâce à ses finitions haut de gamme. Il allie confort thermique et design contemporain.

Le poêle à granulés Olzone 6 offre un superbe design contemporain avec sa structure en acier noir et gris, ses arêtes arrondies et son très élégante vitre plane noire.

The Olzone pellet stove is very quiet thanks to its high quality finish. It combines thermal comfort with contemporary design.

The Olzone 6 pellet stove offers a superb contemporary design with its black and grey steel structure, its rounded edges and its very elegant black flat glass.



Poêle avec structure en acier et vitre sérigraphiée noire.

Stove with steel structure and black screen-printed glass.

Couleurs disponibles



Noir
Black

| | |
|--|---------------------------------|
| Dimensions / Dimensions | 583 x 524 x 1199 mm (L x P x H) |
| Combustible | |
| Puissance | 6.2 kW |
| Classe énergétique | A+ |
| Rendements énergétique (minimale / maximale) | 95.69 / 94 |
| Capacité du réservoir (en kg) | 15 |

TETRA 6 & 8

Ses performances vous permettront une restitution de la chaleur quasi totale. Il est aussi équipé d'une télécommande infra-rouge permettant sa programmation.

Its performance will allow you an almost total restitution of heat. It is also equipped with an infrared remote control allowing its programming.

TETRA 6 & 8



Couleurs disponibles en option



Bleu texturé
Textured blue



Vert texturé
Textured green



Orange texturé
Textured orange



Taupe texturé
Textured mole



Blanc texturé
Textured white



Gris anthracite
Charcoal grey



Gris clair texturé
Light grey



Rouge texturé
Textured red



Noir texturé
Textured black

Poêle avec structure en acier.
Stove with steel structure.

Etanche 50 PA

Couleurs disponibles



Blanc
White



Noir
Black



Rouille
Rust

TETRA 6

Dimensions cadre / Frame Dimensions **485 x 485 x 1090mm (L x P x H)**

Combustible



Puissance

6.5 kW

Classe énergétique

A+

Rendement énergétique (minimale / maximum)

94 / 92.5

Capacité du réservoir (en kg)

24

TETRA 8

Dimensions cadre / Frame Dimensions **485 x 485 x 1090 mm (L x P x H)**

Combustible



Puissance

8 kW

Classe énergétique

A+

Rendement énergétique (minimale / maximum)

93 / 90

BALT 6 & 8

Son rendement exceptionnel de 92,5% à puissance nominale vous procurera une chaleur douce et enveloppante dans tout l'espace de vie. Une température programmable pour une consommation maîtrisée.

Its exceptional efficiency of 92.5% at nominal power will give you a soft and enveloping heat throughout the living space. This pellet stove offers a programmable temperature for controlled consumption.



Couleurs disponibles en option



Poêle avec structure en acier.
Stove with steel structure.

Etanche 50 PA

Couleurs disponibles



BALT 6

| | |
|--|--------------------------------|
| Dimensions cadre / Frame Dimensions | 484 x 484 x 942 mm (L x P x H) |
| Combustible | |
| Puissance | 6.5 kW |
| Classe énergétique | A+ |
| Rendement énergétique (minimale / maximum) | 94 / 92.5 |
| Capacité du réservoir (en kg) | 20 |

BALT 8

| | |
|--|--------------------------------|
| Dimensions cadre / Frame Dimensions | 484 x 484 x 942 mm (L x P x H) |
| Combustible | |
| Puissance | 8 kW |
| Classe énergétique | A+ |
| Rendement énergétique (minimale / maximum) | 93 / 90 |



E-PAKE

Opter pour une ambiance chaleureuse et cosy avec ce poêle à granulés ! E PAKE prendra peu de place dans votre pièce se fera discret, mais également, il restera un mobilier très design et contemporain procurant des fonctionnalités enrichissantes avec des options implacable.

Opt for a warm and cosy atmosphere with this pellet stove! E PAKE will take up little space in your room and will be discreet, but it will also remain a very design and contemporary piece of furniture providing enriching functionalities with relentless options.

E-PAKE



Poêle avec structure en acier et vitre sérigraphiée noire.

Stove with steel structure and black screen-printed glass.

Couleurs disponibles



Noir
Black



Dimensions / Dimensions

988 x 260 x 985 mm (L x P x H)

Combustible



Puissance

7.6 kW

Classe énergétique

A+

Rendements énergétique (minimale / maximale)

92.9 / 90.7

Capacité du réservoir (en kg)

17

E-WALL EVO 8C

Ce poêle à pellets étroit de 28 cm de profondeur s'intégrera parfaitement dans les espaces restreints.

This 28cm deep narrow pellet stove will fit perfectly in smaller spaces.



Poêle à granulés avec structure en acier.

Pellet stove with steel structure.

Couleurs disponibles



Blanc et Noir
White and Black



Rouille et Noir
Rust and Black



Canalisé



Dimensions / Dimensions

1030 x 280 x 1010 mm (L x P x H)

Combustible



Puissance

7.6 kW

Classe énergétique

A+

Rendements énergétique (minimale / maximale)

92.9 / 90.7

Capacité du réservoir (en kg)

18

BOIS

WOOD

Poêle en acier
Steel stove.



10,31 kW



Longueur de bûche : 50 cm
Log length : 50 cm

DIMENSIONS (mm)
DIMENSIONS

| L W | P D | H H |
|--------|--------|--------|
| 1042 | 441 | 967 |

Rendement énergétique : 77.1 %

Classe énergétique : A



OSSAU





MALLET

Poêle en acier
Steel stove.

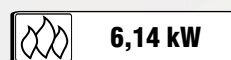

Longueur de bûche : 12 cm
Log length : 12 cm

DIMENSIONS (mm)
DIMENSIONS

| L W | P D | H H |
|--------|--------|--------|
| 484 | 484 | 1209 |

Rendement énergétique : **81.70 %**

Classe énergétique : **A+**



ANETO

Aux caractéristiques surprenantes, ce poêle à bois vous apportera chaleur et un confort garanti. D'une forme arrondie, l'ANETO s'adaptera parfaitement aux angles et aux coins les plus étroits de votre pièce.

With its surprising characteristics, this wood stove will bring you warmth and guaranteed comfort. With its rounded shape, the ANETO stove will fit perfectly into the narrowest corners of your room.



ANETO



Poêle en acier.
Steel stove.

Dimensions / Dimensions

582 x 426 x 1195 mm (L x P x H)

Combustible / Fuel



Puissance / Power

7,6 kW

Classe énergétique / Energy class

A

Rendement énergétique / Efficiency

75.1 %



Longueur de bûche : 15 cm
Log length : 15 cm

Couleur disponible
Available Color



Noir
Black

ASPIN

Le poêle à bois Aspin présente une puissance nominale de 7 kW avec un design rustique tout en conservant l'aspect moderne d'un poêle à bois qui respecte ses capacités techniques.

The Aspin wood stove has a nominal power of 7 kW with a rustic design while maintaining the modern look of a wood stove that respects its technical capabilities.



Poêle en acier, couleur anthracite,
équipé de la double combustion.

*Steel stove, anthracite colour,
equipped with double combustion.*



Longueur de bûche : 33 cm
Log length : 33 cm

Dimensions / Dimensions

480 x 480 x 1143 mm (L x P x H)

Combustible / Fuel



Puissance / Power

7 kW

Classe énergétique / Energy class

A +

Rendement énergétique / Efficiency

80.4 %



AUBIS

Poêle à bois en acier et porte latérale pour accéder au chargement de bois. Design arrondi pour une discrétion dans n'importe quel design de pièce. Un poêle d'exception avec une classe énergétique A+

Steel wood stove and side door to load wood. Rounded design for discretion in any room design. An exceptional stove with an energy class A +



Poêle rond en acier.
Round steel stove.



Longueur de bûche : 33 cm
Log length : 33 cm

Dimensions / Dimensions

472 x 472 x 1160 mm (L x P x H)

Combustible / Fuel



Puissance / Power

7,6 kW

Classe énergétique / Energy class

A+

Rendement énergétique / Efficiency

80 %

SOULOR

S'adaptant à tout type de décoration d'intérieur, le SOULOR possède une forme cylindrique avec des couleurs à la fois sobres et élégantes. Grâce à un habillage noir mat et de pierre ollaire, ce poêle à bois dispose d'un design épuré.

Adapting to any type of interior decoration, the SOULOR stove has a cylindrical shape with colours that are both sober and elegant. Thanks to a matt black and soapstone cladding, this wood stove has a pure design.



Poêle rond en acier et pierre ollaire.
Round steel stove and soap stone.



Longueur de bûche : 33 cm
Log length : 33 cm

Dimensions / Dimensions **555 x 555 x 1360 mm (L x P x H)**

Combustible / Fuel



Puissance / Power

7,4 kW

Classe énergétique / Energy class

A

Rendement énergétique / Efficiency

79.3 %



LARY

Le poêle en acier Lary est un modèle intemporel qui trouvera autant sa place au cœur d'un design moderne qu'au sein d'une décoration intérieure plus classique.

The Lary steel stove is a timeless model which will find its place in the heart of modern design as well as in a more classic interior decoration.



Poêle rond en acier.
Round steel stove.



Longueur de bûche : 50 cm
Log length : 50 cm

Dimensions / Dimensions **710 x 510 x 1152 mm (L x P x H)**

Combustible / Fuel



Puissance / Power

8 kW

Classe énergétique / Energy class

A+

Rendement énergétique / Efficiency

80.3 %



EQUINOXE

Facile à vivre et à entretenir, simple à installer dans toutes les pièces de la maison, ce poêle en fonte dispose d'une puissance nominale de 8 kW.

Easy to live with and maintain, easy to install in any room of the house, this cast iron stove has a nominal power of 8 kW.



EQUINOXE

Poêle en fonte anthracite ai design contemporain, équipé de la double combustion.

Cast iron stove with a contemporary design, equipped with double combustion.



Longueur de bûche : 33 cm

Log length : 33 cm

Dimensions / Dimensions **515 x 430 x 1140 mm (L x P x H)**

Combustible / Fuel



Puissance / Power

8 kW

Classe énergétique / Energy class

A

Rendement énergétique / Efficiency

76 %



RUSTIQUE

Poêle à bois Rustique avec ses lignes retro et intemporelles, trouvera sa place autant dans un vieux chalet en bois que dans un décor contemporain adepte de petites touches vintage.

The rustic wood stove with its retro and timeless lines, will find its place as much in an old wooden chalet as in a contemporary decor full of small vintage touches.



Poêle en fonte, couleur anthracite,
équipé de la double combustion.

Cast iron stove, anthracite colour, equipped with double combustion.



Longueur de bûche : 50 cm

Log length : 50 cm

Dimensions / Dimensions

780 x 582 x 790 mm (L x P x H)

Combustible / Fuel



Puissance / Power

11 kW

Classe énergétique / Energy class

A

Rendement énergétique / Efficiency

78 %

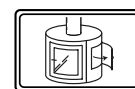

ACTUAL

Petit frère du poêle Modern (poêle à bois au style vintage), Actual associe design harmonieux et qualité technique, gages d'une fabrication Chazelles.

Little brother of the Modern stove, Actual combines harmonious design and technical quality, guarantees of Chazelles manufacture.



Poêle en fonte anthracite au design contemporain, équipé de la double combustion.

Cast iron stove, anthracite colour, equipped with double combustion.

Dimensions / Dimensions **556 x 433 x 723 mm (L x P x H)**

Combustible / Fuel



Puissance / Power

9 kW

Classe énergétique / Energy class

A

Rendement énergétique / Efficiency

79 %

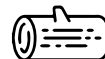

Longueur de bûche : 33 cm

Log length : 33 cm

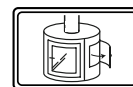

NIRO DA

SCANDIUM



Longueur de bûche : 41 cm
Log length : 41 cm

DIMENSIONS (mm)
DIMENSIONS

| L W | P D | H H |
|--------|--------|--------|
| 460 | 460 | 1000 |

Options : Kit de rotation / rotation kit

Tablette et socle marbre / Marble shelf and base

Rendement énergétique : 80%

Classe énergétique : A+





STANDSTAD

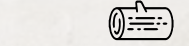

Longueur de bûche : 35 cm
Log length : 35 cm

DIMENSIONS (mm)
DIMENSIONS

| L W | P D | H H |
|--------|--------|--------|
| 460 | 460 | 1255 |

Options : Kit de rotation / rotation kit

Couleurs disponibles



Blanc
White



Noir
Black

Rendement énergétique : **80%**

Classe énergétique : **A+**



SCHMIDT

**7 kW**

Longueur de bûche : 25 cm
Log length : 25 cm



DIMENSIONS (mm)
DIMENSIONS

| L W | P D | H H |
|--------|--------|--------|
| 645 | 480 | 925 |

Rendement énergétique : **81%**

Classe énergétique : **A+**



TIVA L



CONDENSATION

 **7 kW**



Longueur de bûche : 25 cm
Log length : 25 cm

DIMENSIONS (mm)
DIMENSIONS

| L W | P D | H H |
|--------|--------|--------|
| 645 | 480 | 1235 |

**Options : Kit d'accumulation /
accumulation kit**

Classe énergétique : **A+**



Rendement énergétique : **81%**

TIVA XL



CONDENSATION

 **7 kW**



Longueur de bûche : 25 cm
Log length : 25 cm

DIMENSIONS (mm)
DIMENSIONS

| L W | P D | H H |
|--------|--------|--------|
| 645 | 480 | 1235 |

Classe énergétique : **A+**



Rendement énergétique : **81%**

FERRO ELEGANCE

SCHEERER

Poêle carré en acier noir et
vitre miroir teintée.

*Black steel square stove with
tinted mirror glass.*



6 kW



Longueur de bûche : 33 cm
Log length : 33 cm

DIMENSIONS (mm)
DIMENSIONS

| L W | P D | H H |
|--------|--------|--------|
| 400 | 400 | 1500 |

Rendement énergétique : 80%

Classe énergétique : A+



PILA PIERRE OLLAIRE



STANDSTAND

Poêle rond en acier, avec un
entourage pierre ollaire blanche.
*Round steel stove with soapstone
surround.*



Longueur de bûche : 35 cm
Log length : 35 cm

| DIMENSIONS (mm) <i>DIMENSIONS</i> | | |
|--------------------------------------|---------------|---------------|
| L <i>W</i> | P <i>D</i> | H <i>H</i> |
| 525 | 525 | 1510 |

Options : Kit d'accumulation /
accumulation kit

Couleurs disponibles *Available colors*



Blanc
White



Noir
Black



Pierre ollaire
Soap stone

Rendement énergétique : **80%**

Classe énergétique : **A+**



SCANDERANG

CALI

Poêle en acier noir ou blanc, avec vitre pliée pour une meilleure vision du feu.

Stove in black or white steel, with folded glass for a better view of the fire.



6 kW



Longueur de bûche : 38 cm
Log length : 38 cm



DIMENSIONS (mm)
DIMENSIONS

| L W | P D | H H |
|--------|--------|--------|
| 568 | 560 | 1250 |

Couleurs disponibles



Blanc
White



Noir
Black

Rendement énergétique : 80%

Classe énergétique : A+



SCANDERANG

CALI XL

Poêle en acier noir, avec vitre pliée pour une meilleure vision du feu.

Stove in black or white steel, with folded glass for a better view of the fire.



6 kW



Longueur de bûche : 38 cm
Log length : 38 cm



DIMENSIONS (mm)
DIMENSIONS

| L W | P D | H H |
|--------|--------|--------|
| 568 | 560 | 1500 |

Options : Kit d'accumulation /
accumulation kit

Rendement énergétique : 80%

Classe énergétique : A+



ZIO



DESCRIPTION

Poêle rond en acier noir avec porte plate.
Round stove in black steel with a flat door.

 **5 kW**



Longueur de bûche : 40 cm
Log length : 40 cm

DIMENSIONS (mm)
DIMENSIONS

| L <i>W</i> | P <i>D</i> | H <i>H</i> |
|---------------|---------------|---------------|
| 400 | 347 | 1097 |

Rendement énergétique : **80%**
Classe énergétique : **A+**



BELLA NOIR

Poêle en acier noir avec kit accumulateur de chaleur 29kg inclus.

Black steel stove with 29kg heat storage kit included.



6 kW



Longueur de bûche : 47 cm
Log length : 47 cm

DIMENSIONS (mm)
DIMENSIONS

| L W | P D | H H |
|--------|--------|--------|
| 440 | 390 | 1325 |

Rendement énergétique : **80%**

Classe énergétique : **A+**



BELLA BLANC

Poêle en acier noir avec kit accumulateur de chaleur 29kg inclus.

Black steel stove with 29kg heat storage kit included.



6 kW



Longueur de bûche : 47 cm
Log length : 47 cm

DIMENSIONS (mm)
DIMENSIONS

| L W | P D | H H |
|--------|--------|--------|
| 440 | 390 | 1325 |

Rendement énergétique : **80%**

Classe énergétique : **A+**



Poêle en acier noir.
Black steel stove.

Tablette en marbre / Marble shelf

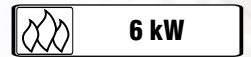

Longueur de bûche : 47 cm
Log length : 47 cm

DIMENSIONS (mm)
DIMENSIONS

| L W | P D | H H |
|--------|--------|--------|
| 530 | 390 | 1255 |

Couleurs disponibles



Blanc
White



Noir
Black



Noir
diamant
Diamond
black



Pierre
ollaire
Soap stone

Rendement énergétique : 79%
Classe énergétique : A



NESTOR MARTIN



WOODBIX® TECHNOLOGY

Permet de combiner la **jouissance de la chaleur** et la **simplicité d'utilisation** avec une **performance exceptionnelle de combustion**.

It combines the benefit of warmth and simplicity with an exceptional combustion performance.



OPTION :

Télécommande thermostatique /
Thermostatic remote control



M43

NESTOR MARTIN

Poêle en fonte, gamme Premium, au design très épuré et moderne.

Modern cast iron stove.

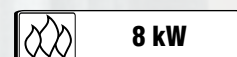

Longueur de bûche : 40 cm
Log length : 40 cm

DIMENSIONS (mm)
DIMENSIONS

| L <i>W</i> | P <i>D</i> | H <i>H</i> |
|---------------|---------------|---------------|
| 696 | 375 | 895 |

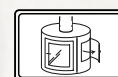

Rendement énergétique : **86 %**

Classe énergétique : **A+**



NESTOR MARTIN

Poêle en acier, gamme Premium, au design très épuré et moderne.

Rotative steel stove.



6 kW



Longueur de bûche : 40 cm

Log length : 40 cm

DIMENSIONS (mm)
DIMENSIONS

| L W | P D | H H |
|--------|--------|--------|
| 1700 | 516 | 834 |

Rendement énergétique : 86 %

Classe énergétique : A+



WOODBBOX® TECHNOLOGY

TQ33



NESTOR MARTIN

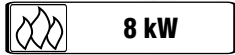

8 kW



Longueur de bûche : 50 cm

Log length : 50 cm

DIMENSIONS (mm)
DIMENSIONS

| L W | P D | H H |
|--------|--------|--------|
| 1700 | 516 | 1039 |

Rendement énergétique : 78 %

Classe énergétique : A

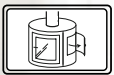

WOODBBOX® TECHNOLOGY

TQH 43



360°



TQH 13

NESTOR MARTIN

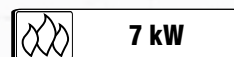

7 kW



Longueur de bûche : 33 cm
Log length : 33 cm

DIMENSIONS (mm)
DIMENSIONS

| L W | P D | H H |
|--------|--------|--------|
| 430 | 355 | 1295 |

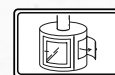

Rendement énergétique : 85 %

Classe énergétique : A+



WOODBOX® TECHNOLOGY

360°



TQH 33

NESTOR MARTIN

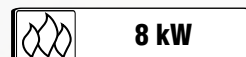

8 kW



Longueur de bûche : 40 cm
Log length : 40 cm

DIMENSIONS (mm)
DIMENSIONS

| L W | P D | H H |
|--------|--------|--------|
| 576 | 434 | 1523 |

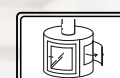

Rendement énergétique : 81 %

Classe énergétique : A+



WOODBOX® TECHNOLOGY

NESTOR MARTIN



Longueur de bûche : 40 cm
Log length : 40 cm

DIMENSIONS (mm)
DIMENSIONS

| L W | P D | H H |
|--------|--------|--------|
| 612 | 457 | 620 |

Option : Télécommande
thermostatique / Thermostatic remote
control

Rendement énergétique : 86 %

Classe énergétique : A+



MQ 33

WOODBOK[®] TECHNOLOGY



S 33

NESTOR MARTIN



6 kW



Longueur de bûche : 40 cm
Log length : 40 cm

DIMENSIONS (mm)
DIMENSIONS

| L W | P D | H H |
|--------|--------|--------|
| 631 | 395 | 752 |

**Option : Télécommande
thermostatique / Thermostatic remote
control**

Rendement énergétique : **86.4 %**

Classe énergétique : **A+**



**WOODBBOX®
TECHNOLOGY**

S 43

NESTOR MARTIN



8 kW



Longueur de bûche : 50 cm
Log length : 50 cm

DIMENSIONS (mm)
DIMENSIONS

| L W | P D | H H |
|--------|--------|--------|
| 735 | 460 | 803 |

**Option : Télécommande
thermostatique / Thermostatic remote
control**

Rendement énergétique : **85 %**

Classe énergétique : **A+**



**WOODBBOX®
TECHNOLOGY**

NESTOR MARTIN

Poêle en fonte aux formes intemporelles.
Cast iron stove.



8 kW



Longueur de bûche : 40 cm
Log length : 40 cm

STANFORD 9 :

DIMENSIONS (mm)
DIMENSIONS

| L W | P D | H H |
|--------|--------|--------|
| 610 | 419 | 723 |

STANFORD 9+ :

DIMENSIONS (mm)
DIMENSIONS

| L W | P D | H H |
|--------|--------|--------|
| 616 | 424 | 783 |

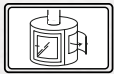

Classe énergétique : A



STANFORD 9 & 9+

Table de cuisson intégré
Integrated cooking plate



NESTOR MARTIN

Poêle en fonte aux formes intemporelles.
Cast iron stove.



12 kW



Longueur de bûche : 50 cm
Log length : 50 cm

STANFORD 12 :

DIMENSIONS (mm)
DIMENSIONS

| L W | P D | H H |
|--------|--------|--------|
| 735 | 570 | 790 |

STANFORD 12+ :

DIMENSIONS (mm)
DIMENSIONS

| L W | P D | H H |
|--------|--------|--------|
| 742 | 520 | 857 |



Classe énergétique : A



STANFORD 12 & 12+





NESTOR MARTIN

Poêle en fonte aux formes intemporelles.
Cast iron stove.

Longueur de bûche : 40 cm
Log length : 40 cm



Longueur de bûche : 50 cm
Log length : 50 cm

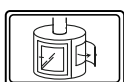

HARMONY I

Dimensions / Dimensions **605 x 368 x 665 mm (L x P x H)**

| | |
|------------------------------------|-------------|
| Combustible / Fuel | |
| Puissance / Power | 8 kW |
| Classe énergétique / Energy class | A |
| Rendement énergétique / Efficiency | 76 % |

HARMONY III

Dimensions / Dimensions **735 x 468 x 745 mm (L x P x H)**

| | |
|------------------------------------|--------------|
| Combustible / Fuel | |
| Puissance / Power | 12 kW |
| Classe énergétique / Energy class | A |
| Rendement énergétique / Efficiency | 76 % |

GAZ

GAS

TQH35



Poêle en acier, fonctionnant au gaz naturel. Finition bûches.

Natural gas steel stove with log finish.

Dimensions / Dimensions

576 x 434 x 1293 mm (L x P x H)

Combustible



Puissance

10kW

Classe énergétique

A+

Les poêles au gaz rendent vivants les espaces où ils se déploient. Leur magie permet de délivrer une flamme instantanée, offrant une chaleur douce et homogène. Ils apportent à leurs utilisateurs confort moderne, esthétique et simplicité d'usage. Aux décorateurs et aux architectes, ils donnent tout un univers à explorer.

Our gas stoves bring life to the spaces in which they are installed. The magic of these stoves allows them to deliver an instantaneous flame, offering a soft and homogeneous heat. They provide their users with contemporary comfort, aesthetics and ease of use. For decorators and architects, they offer a whole universe to explore. Let yourself be surprised.



THS15

NESTOR MARTIN

Poêle en acier, fonctionnant au gaz naturel. Double Face, avec un système de rotation à 360°
Stove with steel structure.



DIMENSIONS (mm)
DIMENSIONS

| L W | P D | H H |
|--------|--------|--------|
| 434 | 200 | 1300 |

Classe énergétique : A+



TQH15

NESTOR MARTIN

Poêle en acier, fonctionnant au gaz naturel. Finition bûches.
Stove with steel structure.



DIMENSIONS (mm)
DIMENSIONS

| L W | P D | H H |
|--------|--------|--------|
| 434 | 365 | 1257 |

Classe énergétique : A+



Poêle en fonte, fonctionnement au gaz, pièce de caractère dans votre design d'intérieur, une pièce rustique réadapté. Discret et efficace, sa puissance de chaleur est modulable selon vos envies avec ses quatre brûleurs signe de modernité technologique.

Cast iron stove, gas powered, character appliance in your interior design, a rehabilitated rustic appliance. Discreet and efficient, its heat output can be adjusted according to your wishes with its four burners, a sign of technological modernity.

NESTOR MARTIN

Poêle en fonte, fonctionnement au gaz.

Cast iron stove .



8.6 kW



DIMENSIONS (mm)
DIMENSIONS

| L W | P D | H H |
|--------|--------|--------|
| 632 | 391 | 754 |

Classe énergétique : **A+**



S45

Une qualité séduisante.

Le modèle S est une modernisation du poêle en fonte classique, avec la technologie de combustion Woodbox®, et une commande à distance en option.

An attractive quality.

The Model S is a retrofit of the conventional cast iron stove with Woodbox® combustion technology and an optional remote control.

S45



NESTOR MARTIN

Poêle en fonte, fonctionnement au gaz.

Cast iron stove.

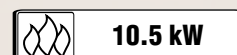

DIMENSIONS (mm)
DIMENSIONS

| L <i>W</i> | P <i>D</i> | H <i>H</i> |
|---------------|---------------|---------------|
| 735 | 426 | 766 |

Classe énergétique : **A+**



UTILISER LE BON BOIS

Bois bien sec (moins de 20% d'humidité), stocké dans un endroit sec et bien aéré.
Le temps de séchage optimal pour un bois sec :

- sous abri : quartiers ou rondins de 33 cm : de 15 à 17 mois
- à l'air libre : stère en quartiers ou rondins de 1 m : de 18 à + de 24 mois

Deux grandes familles d'essence de bois :

- Feuillus durs : chêne, hêtre, frêne, charme, noyer, fruitiers... ; très appréciés pour le chauffage domestique, sauf le châtaignier qui éclate en brûlant.
- Feuillus tendres et résineux : épicéa, sapin, pin, mélèze, peuplier, saule, sont appréciés pour leur montée rapide en température, mais brûlent aussi plus rapidement.

Exclure l'utilisation de :

- Bois souillé (issu de récupération – vieux meubles, chantier de démolition...), car il contient des substances toxiques qui se retrouvent dans les fumées (vernis, peinture, produits de traitement...).
- Bois humide : sa combustion libère davantage de substances polluantes, fournissant 2 fois moins d'énergie qu'un bois sec. Il dégrade prématurément votre appareil (encrassement, corrosion) et l'empêche de fonctionner dans les meilleures conditions.

LABELS

BOIS



Le label NF Bois de chauffage a été créé sous l'impulsion de l'ADEME afin d'inciter les utilisateurs de bois à utiliser un combustible certifié, dont les propriétés clairement définies sont respectées par le fabricant et vérifiées par un organisme indépendant. Les entreprises certifiées garantissent le groupe d'essences, la longueur, le niveau d'humidité et la quantité livrée en stères. (Plus d'infos : www.nfboisdechauffage.org)

Consommation : la consommation moyenne de bois est de 8 stères/an en énergie principale, et de seulement 4 stères en usage d'appoint. (Source SER)

Le bois est actuellement le combustible le moins cher du marché.



CHOOSE A GOOD WOOD

Dry wood (less than 20% moisture content), stored in a dry, well aerated place.
Optimal drying time for dry wood:

- under cover: 33 cm logs or pieces: from 15 to 17 months
- in the open air: stee of 1 metre logs or pieces: from 18 to 24+ months

Two families of tree species:

- **Hardwoods:** oak, beech, ash, hornbeam, walnut, fruit trees, etc. – much better for household heating, with the exception of chestnut, which sends up sparks when burned.
- **Softwoods:** spruce, fir, pine, larch, poplar and willow are all to be appreciated for the quick heat they provide, but they also burn more quickly.

Avoid using:

- Soiled wood (recovered from old furniture, demolition sites, etc.), as it contains toxic matter that is released in the smoke it gives off (varnish, paint, processing products, etc.).
- Damp wood: burning it releases more pollutants and gives off half the energy of dry wood. It also leads to premature degradation of your appliance (sooting up and corrosion) and prevents it from operating under the best conditions.

CERTIFICATION

WOOD

The NF 'Bois de chauffage' label was created by the ADEME organism with the aim of encouraging wood users to use a certified fuel which properties are respected by the manufacturer and checked by an independent body. Certified companies guarantee group of species, length, moisture content level and quantity delivered in steers. (For more information: www.nfboisdechauffage.org)

Consumption: average wood consumption is 8 steers/year in main heating, and only 4 steers in back-up use. (Source: SER)

Wood is currently the cheapest fuel on the market.

GRANULÉS

Les granulés certifiés DIN+, EN+ et NF Biocombustibles solides granulés (bois qualité Haute Performance) assurent une combustion optimale. La certification assure que les produits répondent bien aux normes.

Seuls les granulés labellisés comme ci-dessous sont autorisés comme combustible.

Nouveau label - Fortement recommandé

Les granulés de bois sont des cylindres de sciures compressés, entièrement naturels (sans ajout de liant chimique). Les granulés peuvent être fabriqués à partir de sciure de résineux ou de feuillus d'un diamètre moyen de 6 mm et d'une longueur comprise entre 20 et 30 mm. Les granulés bois doivent être utilisés exclusivement dans des poêles ou inserts à granulés.



PELLETS

Pellets certified DIN+, EN+ and NF Solid biofuel pellets (quality wood high performance), ensure an optimal combustion. Only the certified pellets (please refer to the logo below) are allowed to be used as fuel.

New label – Highly recommended

Wood pellet are cylindrical compressed sawdust, entirely natural (without any chemicals). Pellet can be made with sawdust from hardwood or softwood, with an average diameter of 6 mm and a length comprises between 20 and 30 mm. Wood pellet must be used exclusively in pellet stoves or inserts.



UTILISER UN APPAREIL CHAZELLES LABELLISÉ FLAMME VERTE

- Grâce au label Flamme Verte, les Cheminées de Chazelles garantissent leurs appareils conformes aux normes en vigueur, respectant le seuil minimum de rendement et le taux maximum de polluants, c'est à dire moins consommateurs de bois et peu polluants.
- Le rendement correspond à la quantité de chaleur restituée par le combustible lorsqu'il brûle dans un insert ; le reste part en fumée. Le rendement d'un appareil de chauffage dépend aussi beaucoup des caractéristiques du combustible.
- Bon à savoir : Le passage d'un rendement de 50 à 70% permet d'économiser près de 30% de bois.
- Les cheminées ouvertes ne sont pas considérées comme des appareils de chauffage, leur rendement étant inférieur à 10%.

USE A CHAZELLES APPLIANCE WITH THE 'FLAMME VERTE' LABEL

- With the 'Flamme Verte' label, Cheminées de Chazelles attests that its appliances are conform to the standards currently in force, in compliance with the minimum output threshold and the maximum pollution rate – which means that the appliances consume less wood and cause little pollution.
- Output corresponds to the amount of heat given off by the fuel when it is burning in an insert; the rest goes up as smoke. A heating appliance's output depends also very much on the characteristics of the fuel used.
- Useful to know: Going from 50 to 70% output economises almost 30% in terms of wood consumption.
- Open fireplaces are not considered as heating appliances, as their output is less than 10%.

LE LABEL QUALIBOIS, UNE GARANTIE POUR L'INSTALLATION

- QualiBois est un label désignant un équipement de qualité pour les chauffages alimentés par des biocombustibles tels que les bûches et les granulés.
- QualiBois est un gage de sérieux et de qualité pour les entreprises qualifiées installant des inserts et poêles, pour la production de chauffage et d'eau chaude sanitaire.
- Reconnu « Grenelle Environnement », le label QualiBois est une appellation de confiance recommandée par l'ADEME et les collectivités territoriales.

QUALIBOIS. WARRANTY FOR A GOOD INSTALLATION

- QualiBois label certifies the quality of heating appliances installation.
- QualiBois is a warranty of reliability and quality for qualified companies installing inserts and stoves (wood and pellets), for heating and producing hot water.
- QualiBois is a reliable label recommended by ADEME and local authorities (France).





L'ÉMOTION
GAZ

CHAZELLES MEMBRE DE L'ASSOCIATION L'EMOTION GAZ

Objectifs de l'association

- Promouvoir la mise sur le marché d'appareils indépendants fonctionnant au gaz, de type poêles, inserts, cheminées,
 - Développer et promouvoir une vision partagée de ces produits intégrant notamment le développement durable, la performance énergétique et environnementale,
 - Promouvoir, par le biais de manifestations commerciales, conférences ou formations, les stratégies collectives innovantes dans le domaine du chauffage au gaz,
 - Développer l'activité tout en prenant en compte la complexité
- environnementale. Se concerter sur la législation en vigueur, les bonnes pratiques,
- Etre force de proposition pour l'amélioration des conditions de raccordement à l'alimentation, à l'évacuation et aux conditions de mise en œuvre en général,
 - L'association et la mise en commun d'atouts complémentaires ont pour but de créer une synergie beaucoup plus grande pour l'ensemble de ses membres.

LES MATÉRIAUX AUTHENTIQUES

AUTHENTIC MATERIALS

PIERRES

STONES

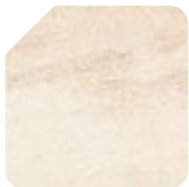

Blanche ramagée
Fossil-encrusted white



Gard
Gard



Brétignac
Brétignac



Bourgogne dorée
Golden Burgundy



Mauzens
Mauzens



Castillon
Castillon



Chazelles
Chazelles

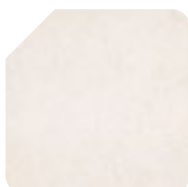

Estailades
Estailades



Tervoux
Tervoux



Fontbelle
Fontbelle

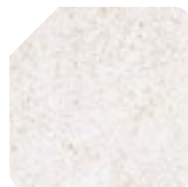

Blanche dorée
Golden white

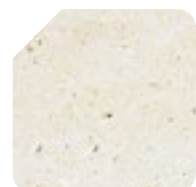

Pierre Blonde
White stone



Pierre de Martigny dorée Ep. 3.
Martigny stone Th. 3.

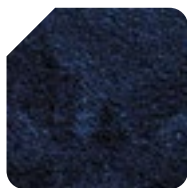

Roche Noire Ep. 2.3.5.8.10.25
Black rock



Roche bleue Ep. 2. 3. 5. 8.
10. 25.
Blue rock Th. 2. 3. 5. 8.
10. 25.



Pierre de Doura
Doura stone



Pierre Moka
Moka stone

GRANITS

GRANITES



Noir Zimbabwe Ep. 2. 3.
Zimbabwe black Th. 2. 3.



Noir Zimbabwe tranché Ep. 2. 3.
Sliced Zimbabwe black Th. 2. 3.

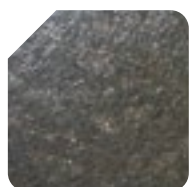

Noir Antique Ep. 2. 3.
Antic black Th. 2. 3.



Noir Zimbabwe effet Cuir Ep. 2. 3.
Zimbabwe black
leather finishing Th. 2. 3.

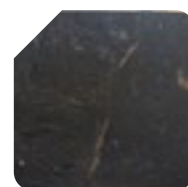

Barocco vintage Ep. 2. 3.
vitange Barocco Th. 2. 3.

BRIQUETTES

BRICKS



5 Rouge flammé
5 Stippled red



3 Rouge flammé
3 Stippled red



5 Sable moulées main
5 hand molded sand



5 Rosée moulées main
5 hand molded frosted



20 x 40 Dalle réfractaire
beige
20 x 40 beige refractory slab



11 x 22 Dalle réfractaire
noire
20 x 40 black refractory slab



Tuilot rustique
Rustic tile



11 x 11 Terre cuite
11 x 11 Terra cotta



5 Clair flammé
5 light stippled



5 Cévennes /
1 seul champ visible
5 Cévennes style
1 single visible field



Briques Ebène parement externe
Non refractory Ebony bricks

BOIS

WOODS



CHENE * / OAK *

* Bois issu de forêts gérées durablement
* wood from sustainably managed forests

Le chêne est une matière naturelle et vivante. Les fissures ou retraits ne peuvent être considérés comme des défauts.

Oak is a natural, living material. Cracks or chips cannot be considered as flaws.



Des plaques fonte décoratives, verticales et horizontales, doivent être obligatoirement installées dans l'âtre de votre cheminée afin de protéger les briques des chocs thermiques.

Decorative cast iron plates, vertical and horizontal, must be installed around your fireplace to protect the bricks from thermal shocks.

MOELLONS / BRIQUES

CINDERBLOCK



Saintonge opus roman
Saintonge Roman style



Bourgogne opus roman
Burgundy Roman style



St Yrieix opus roman
St. Yrieix Roman style

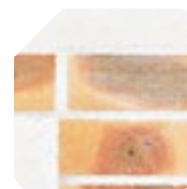

Briquettes maçonnées Brétignac
Brétignac masonry brick



Saintonge assisé, joints pleins
Saintonge paving blocks,
full joints



Bourgogne assisé
Burgundy paving blocks



St Yrieix assisé
St. Yrieix paving blocks



Pierre de pays
Country style stone



Pierre de montagne
Mountain stone



Briquettes maçonnées Saintonge
Saintonge masonry bricks

Toutes matières sur commande. Coloris et assemblage des matériaux présentés sur cette documentation non contractuels.
All materials on command. Shades and assembly of materials shown in this documentation are non-binding.

MARBRES

MARBLE

* Micro fissuré natrellement
Natural micro-cracks

ARDOISE

SLATE

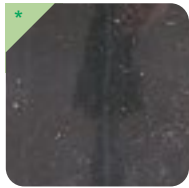

Marquina. Ep. 2. 3.
Marquina. Th. 2. 3.



Arabescato. Ep. 3.
Arabescato. Th. 3.



Rouge Alicante. Ep. 2. 3.
Alicante Red. Th. 2. 3.



Ep. 2. 3.
Th. 2. 3.



Rose Estremoz. Ep. 2. 3.
Estremoz Pink. Th. 2. 3.

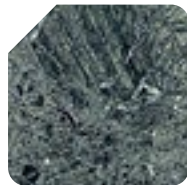

Vert Olympia. Ep. 2. 3.
Olympia Green. Th. 2. 3.

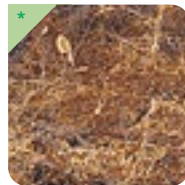

Emperador. Ep. 2. 3.
Emperador. Th. 2. 3.

WENGÉ

WENGE

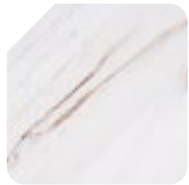

Palissandre Ep. 3.
Palissandre Th. 3.



Almería brossé Ep. 3.
Brushed Alméria Th. 3.



Beige Tiréno Ep. 2. 3.
Beige Tiréno Th. 2. 3.



Ep. 3.
Th. 3.

MARBRES DÉCO

DECORATIVE MARBLE

BROSSÉS BRUSHED



Cannelle brossé Ep. 2.
Brushed cinnamon Th. 2.



Anthracite brossé Ep. 2.
Brushed anthracite Th. 2.



Chocolat brossé Ep. 2.
Brushed chocolate Th. 2.



Gris brossé Ep. 2.
Brushed grey Th. 2.

PAILLETÉS SPANGLED

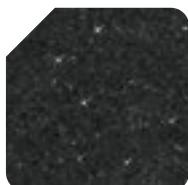

Noir pailleté Ep. 2.
Spangled black Th. 2.

Ces matériaux sont utilisables avec la Gamme gaz et ne doivent en aucun cas être soumis directement au feu.

These materials can be used with the Gas Flame Line and must not at any time be subjected directly to fire.

BRILLANTS SHINING

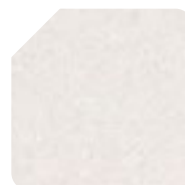

Polaire brillant Ep. 2.
Shining polar Th. 2.



Cappuccino Ep. 2.
Cappuccino Th. 2.

Toutes matières sur commande. Coloris et assemblage des matériaux présentés sur cette documentation non contractuels.
All materials on command. Shades and assembly of materials shown in this documentation are non-binding.



Chazelles

L'art de vivre côté jardin

THE ART OF GARDEN LIVING



Patrimonio.

Cuisine d'été en pierre de Fontbelle patinée, briquettes de 5 claire flammé pour grill complet Chazelles, avec four à pain grand modèle.

Ménuiserie en chêne et plaqué chêne. Plan cuisine en pierre de Bourgogne dorée.

Patrimonio.

Summer kitchen in patined Fontbelle stone, 5 cm clear flame briquettes for full Chazelles grill, with large bread oven.

Oak beams, furniture and shelves. Kitchen plan made of polished gold Burgundy stone.



MEDOC



VOUGEOT



POMEROL

↕ 202 x 80 x 233 cm G= 2

Ce barbecue est votre mini cuisine d'été, il saura répondre à toutes vos envies gustatives.

This barbecue is your mini summer kitchen, it will meet all your taste desires.

↕ 245 x 64 x 212 cm G= 2

Le modèle Vougeot offre de grands plans de travail de chaque côté de son grill complet.

The Vougeot model offers large worktops on either side of its complete grill.

↕ 236 x 109 x 258 cm G= 2

Conçu en pierre de Fontbelle et briquettes de 5 jaune cendré, le barbecue Pomerol se dresse avec splendeur dans les jardins spacieux et conviviaux

Designed in stone of Fontbelle and briquettes of 5 ash yellow, the barbecue Pomerol stands with splendor in the spacious and friendly gardens.

GRILS & BARBECUES

GRILLS & BARBECUES



G62

G= 2

72 x 47 x 27 cm

52 x 40 x 17,5 cm



G64

G= 2

72 x 47 x 44 cm

56 x 34 x 5 cm

Gril G64 G64 grill



2 positions pour la sole foyère
verticale et horizontale.
2 positions for the vertical and
horizontal heart.



2 positions de
réglage pour la
broche.
2 positions for the spit.



3 positions pour la hauteur de la
grille de cuisson.
3 height positions for the cooking
grid.



Encoches pour poser les
brochettes.
Notches for brochettes.



Tiroir à cendres.
Ash drawer.



Accessoires.
Accessories.

Spécialiste du feu sous toutes ses formes, Chazelles proposent également une collection de barbecues et d'accessoires pour tous types de grillades.

Fire specialist in all its forms, Chazelles also offers a collection of barbecues and accessories for all kind of grills.



Plancha Chambord 60

Appareil de cuisson d'extérieur à poser, largeur cuisson 57 cm. 2 brûleurs double rampes, avec sécurité gaz 6000W.

Allumage électronique. Plaque en fonte émaillée multicouche 7mm

Goulotte de récupération des jus. Marquage CE.

Alimentation : butane, propane, gaz naturel (en option).

Nombre de convives : 6 à 8 personnes

Plancha Charbord 60

Outdoor freestanding cooking appliance, cooking width 57 cm.

2 double ramp burners, with gas safety 6000W.

Electronic ignition. 7 mm multilayer enameled cast iron plate

Juice collection chute. CE marking.

Power supply: butane, propane, natural gas (optional).

Number of guests : from 6 to 8 people



TABLE PLANCHA

Ref. CMI 60

28 kg

Acacia & Inox



92 x 123 x 45 cm

BRASERO GM

 **440 kg**



DIMENSIONS (mm)
DIMENSIONS

| L W | P D | H H |
|--------|--------|--------|
| 160 | 90 | 93.54 |

Type de plaque
Plate type

Acier
Steel

Matériaux
Materials

Acier
Steel

Dimension de cuisson
Cooking size

1100

Nombre de convives
Number of guests

20
à +50

BRASERO PM

 **120 kg**



DIMENSIONS (mm)
DIMENSIONS

| L W | P D | H H |
|--------|--------|--------|
| 76 | 76 | 90 |

Type de plaque
Plate type

Acier
Steel

Matériaux
Materials

Acier
Steel

Dimension de cuisson
Cooking size

400

Nombre de convives
Number of guests

20











INFORMATIONS TECHNIQUES / TECHNICAL INFORMATION

| MODELES | PUISSANCE THERMIQUE MAXI (kW) | PUISSANCE THERMIQUE MINI (kW) | RENDEMENT ÉNERGÉTIQUE MAXI | RENDEMENT ÉNERGÉTIQUE MINI | CAPACITÉ DU RÉSERVOIR (kg) | TAUX DE MONOXYDE DE CARBONE (CO à 13% O2) | TYPE TÉLÉCOMMANDE | RACCORDEMENT POUR L'ÉVACUATION DES FUMÉES (mm) | POSITION DU RACCORDEMENT ÉVACUATION FUMÉE | RACCORDEMENT POUR L'ENTRÉE D'AIR DE COMBUSTION (mm) | DIMENSIONS TOTALES (cm) Largeur x Profondeur x Hauteur | POIDS NET DE L'APPAREIL (kg) | GARANTIE (Année) |
|--------------------|-------------------------------|-------------------------------|----------------------------|----------------------------|----------------------------|---|-------------------|--|---|---|---|------------------------------|------------------|
| | | | | | | | | | | | | | |
| INSERTS GRANULES | | | | | | | | | | | | | |
| FACEL 500 EVO | 10,70 | 5,20 | 90,30 | 91,90 | 60,00 | 0,01% | RADIO | 80 | ARRIÈRE | 80 | 81 X 58,3 X 128,08 | 130 | 2 |
| FACEL 500 VERTICAL | 13,80 | 5,30 | 88,40 | 93,80 | 45,00 | 0,01% | RADIO | 80 | ARRIÈRE OU DESSUS | 80 | 51 X 64 X 146 | 175 | 2 |
| FACEL 800 EVO | 13,00 | 6,40 | 90,30 | 91,90 | 60,00 | 0,01% | RADIO | 100 | ARRIÈRE | 80 | 120 X 80 X 160 | 160 | 2 |
| FACEL 800 3V | 14,00 | 5,10 | 85,00 | 88,50 | 50,00 | 0,02% | RADIO | 100 | ARRIÈRE | 80 | 73.2 X 80 X 145 | 234 | 2 |
| FACEL 800 VAD-VAG | 14,00 | 5,10 | 85,00 | 88,50 | 50,00 | 0,02% | RADIO | 100 | ARRIÈRE | 80 | 79.7 X 73.2 X 145.6 | 225 | 2 |
| FACEL 1000 EVO | 15,30 | 6,9 | 90,8 | 93,7 | 60,00 | 0,01% | RADIO | 100 | ARRIÈRE | 80 | 101 X 58,5 X 128,8 | 185 | 2 |
| ATMOS 70 | 6,20 | 2,80 | 91,20 | 92,20 | 12,00 | 0,02% | RADIO | 80 | DESSUS | 50 | 68.7 X 57.6 X 47 | 84 | 2 |
| ATMOS 80 | 9,80 | 4,10 | 92,70 | 94,50 | 15,00 | 0,007% | RADIO | 80 | DESSUS | 80 | 80 X 58.2 X 57.8 | 128 | 2 |













INFORMATIONS TECHNIQUES / TECHNICAL INFORMATION

| MODELES | PUISSANCE NOMINALE (kW) | RENDEMENT ÉNERGÉTIQUE MAXI(%) | LONGUEUR DE BÛCHES (cm) | VENTILATION | TAUX DE MONOXYDE DE CARBONE (CO à 13% O2) | RACCORDEMENT POUR L'ÉVACUATION DES FUMÉES (mm) | POSITION DU RACCORDEMENT ÉVACUATION FUMÉE | RACCORDEMENT POUR L'ENTRÉE D'AIR DE COMBUSTION (mm) | DIMENSIONS TOTALES (cm) Largeur x Profondeur x Hauteur | POIDS NET DE L'APPAREIL (kg) | GARANTIE (Année) |
|-----------------------|-------------------------|-------------------------------|-------------------------|-------------|---|--|---|---|---|------------------------------|------------------|
| | | | | | | | | | | | |
| INSERTS BOIS | | | | | | | | | | | |
| VN 70 | 8 | 77 | 40 | OUI | 0,11 | 150 | DESSUS | 80 | 77,8 X 53,6 X 58,5 | 120 | 5 |
| VN 80 | 8 | 79 | 50 | OUI | 0,09 | 180 | DESSUS | 80 | 87,7 X 51,4 X 58,3 | 140 | 5 |
| VE1000 | 7 | 79 | 50 | - | 0,12 | 200 | DESSUS | 100 | 98 X 46,6 X 52 | 162 | 10 |
| CLOUD 70 R VAD | 9,5 | 80 | 50 | - | 0,1 | 180 | DESSUS | 125 | 72,4 X 48,3 X 154 | 260 | 5 |
| CLOUD 70 R VAG | 9,5 | 80 | 50 | - | 0,1 | 180 | DESSUS | 125 | 72,4 X 48,3 X 154 | 260 | 5 |
| CLOUD 70 3V | 11 | 78 | 50 | - | 0,1 | 180 | DESSUS | 125 | 75,6X48,6X162 | 280 | 5 |
| CLOUD 90 R VAD | 12,7 | 79 | 70 | - | 0,1 | 200 | DESSUS | 125 | 94,7X48,3X161 | 310 | 5 |
| CLOUD 90 R VAG | 12,7 | 79 | 70 | - | 0,1 | 200 | DESSUS | 125 | 94,7X48,3X161 | 310 | 5 |
| CLOUD 90 R 3V | 11,9 | 76,7 | 70 | - | 0,09 | 200 | DESSUS | 125 | 92,2X52,3X162 | 360 | 5 |
| CLOUD 100 RDF | 12 | 78 | 50 | - | 0,12 | 200 | DESSUS | 125 | 96,4X58,1X160,6 | 350 | 5 |
| CLOUD 100 R | 12 | 83 | 50 | - | 0,08 | 200 | DESSUS | 125 | 97X54,6X154,1 | 345 | 5 |
| CLOUD 80 R | 12,1 | 76,87 | 60 | - | 0,08 | 200 | DESSUS | 125 | 84,8X55,3X184,4 | 305 | 5 |
| CLOUD 100 R HORIZON | 13,2 | 77,96 | 80 | - | 0,09 | 200 | DESSUS | 150 | 107X56,3X147,5 | 370 | 5 |
| CLOUD 100 RDF HORIZON | 12,5 | 78,46 | 50 | - | 0,08 | 200 | DESSUS | 125 | 97X58X135 | 350 | 5 |
| CLOUD 130 R | 16 | 78,14 | 50 | - | 0,09 | 230 | DESSUS | 125 | 137X56,5X147 | 460 | 5 |
| CLOUD 120 RDF HORIZON | 16,5 | 79,7 | 50 | - | 0,1 | 200 | DESSUS | 125 | 127X67X135 | 430 | 5 |
| CLOUD 150 R | 18,8 | 80,8 | 50 | - | 0,08 | 250 | DESSUS | 125 | 157X56,5X147 | 535 | 5 |

INFORMATIONS TECHNIQUES / TECHNICAL INFORMATION

| MODELES | PUISSANCE NOMINALE (kW) | RENDIMENT ÉNERGETIQUE (%) | LONGUEUR DE BÛCHES (cm) | VENTILATION | TAUX DE MONOXYDE DE CARBONE (CO à 13% O2) | RACCORDEMENT POUR L'ÉVACUATION DES FUMÉES (mm) | POSITION DU RACCORDEMENT ÉVACUATION FUMÉE | RACCORDEMENT POUR L'ENTRÉE D'AIR DE COMBUSTION (mm) | DIMENSIONS TOTALES (cm) Largeur x Profondeur x Hauteur | POIDS NET DE L'APPAREIL (kg) | GARANTIE (Année) |
|--------------|---|---|---|---|---|---|---|--|---|---|---|
| |  |  |  |  |  |  |  |  |  |  |  |
| INSERTS BOIS | | | | | | | | | | | |
| IQ33 | 7,9 | 71,1 | 40 | OUI | 0,08 | 150 | DESSUS | 100 | 58,4 X 45 X 64,4 | 135 | 2 |
| IQ43 | 11 | 71,2 | 55 | OUI | 0,09 | 180 | DESSUS | 100 | 69,2 X 49,8 X 66,6 | 182 | 2 |
| IQH33 | 8 | 81,4 | 40 | OUI | 0,08 | 180 | DESSUS | 100 | 58,4 X 45 X 91,2 | 178 | 2 |
| IQH43 | 14,7 | 77,3 | 50 | OUI | 0,08 | 180 | DESSUS | 100 | 69,2 X 49,8 X 84,8 | 197 | 2 |

INFORMATIONS TECHNIQUES / TECHNICAL INFORMATION











| MODELES | PUISSANCE THERMIQUE MAXI (kW) | PUISSANCE THERMIQUE MINI (kW) | RENDIMENT ÉNERGETIQUE MAXI | RENDIMENT ÉNERGETIQUE MINI | CAPACITÉ DU RÉSERVOIR (kg) / LONGUEUR BUCHE | TAUX DE MONOXYDE DE CARBONE (CO à 13% O2) | TYPE TÉLÉCOMMANDE | RACCORDEMENT POUR L'ÉVACUATION DES FUMÉES (mm) | POSITION DU RACCORDEMENT ÉVACUATION FUMÉE | RACCORDEMENT POUR L'ENTRÉE D'AIR DE COMBUSTION (mm) | DIMENSIONS TOTALES (cm) Largeur x Profondeur x Hauteur | POIDS NET DE L'APPAREIL (kg) | GARANTIE (Année) | RESTITUTION CALORIFIQUE SUR CIRCUIT EAU (kW) |
|------------------|---|-------------------------------|---|----------------------------|---|---|---|---|---|---|--|---|---|---|
| |  | |  | |  |  |  |  |  |  |  |  |  |  |
| INSERTS HYDRO | | | | | | | | | | | | | | |
| FACEL 1000 HYDRO | 31,5 | 8,90 | 91 | 94 | 90 KG | 0,02% | RADIO | 100 | ARRIÈRE | 80 | 112,5 X 61,4 X 146 | 232,00 | 2 | 18 |
| CLOUD 80R HYDRO | 14,5 | - | 84 | - | 50 CM | 0,1% | - | 180 | DESSUS | 125 | 84,8X60,8X157,4 | 390 | 5 | 7 |

Les informations mentionnées dans ce catalogues sont données à titre indicatif et peuvent évoluer dans le cadre de l'amélioration continue des produits. Pour toute information, consultez les fiches techniques des produits.

The information in this catalogue is indicative and may change as a result of continuous product improvement. For further information, please consult the technical data sheets of each device.











INFORMATIONS TECHNIQUES POÊLES GRANULÉS

TECHNICAL INFORMATION PELLET STOVE

| MODELES | PUISSANCE THERMIQUE MAXI (kW) | PUISSANCE THERMIQUE MINI (kW) | RENDEMENT ÉNERGÉTIQUE MAXI | RENDEMENT ÉNERGÉTIQUE MINI | CAPACITÉ DU RÉSERVOIR (kg) | TAUX DE MONOXYDE DE CARBONE (CO à 13% O2) | TYPE TÉLÉCOMMANDE | RACCORDEMENT POUR L'ÉVACUATION DES FUMÉES (mm) | POSITION DU RACCORDEMENT ÉVACUATION FUMÉE | RACCORDEMENT POUR L'ENTRÉE D'AIR DE COMBUSTION (mm) | DIMENSIONS TOTALES (cm) Largeur x Profondeur x Hauteur | POIDS NET DE L'APPAREIL (kg) | GARANTIE (Année) |
|-------------------|---|-------------------------------|---|----------------------------|---|---|---|---|--|---|---|---|---|
| |  | |  | |  |  |  |  |  |  |  |  |  |
| POELES À GRANULES | | | | | | | | | | | | | |
| ICONIC O | 8,5 | 4 | 91,9 | 94,2 | 17 | 0,003 | - | 80 | ARRIÈRE OU DESSUS | 60 | 55,4 X 55,9 X 121 | - | 2 |
| ICONIC S | 8,5 | 3,7 | 94 | 95,3 | 40 | 0,003 | - | 80 | ARRIÈRE OU DESSUS | 60 | 95,8 X 41 X 120,6 | - | 2 |
| ICONIC C | 8,5 | 4,2 | 94,4 | 92,5 | 32 | 0,003 | - | 80 | ARRIÈRE OU DESSUS | 60 | 56,5 X 64,3 X 119,6 | - | 2 |
| BALT 6 | 6,5 | 2,5 | 92,5 | 94 | 15 | 0,01 | INFRA-ROUGE | 80 | ARRIÈRE | 50 | 48,4 X 48,4 X 94,2 | 98 | 2 |
| BALT 8 | 8 | 2,4 | 90 | 93 | 15 | 0,02 | INFRA-ROUGE | 80 | ARRIÈRE | 50 | 48,4 X 48,4 X 94,2 | 98 | 2 |
| E-PAKE | 7,6 | 3,7 | 90,7 | 92,9 | 17 | 0,014 | RADIO | 80 | DESSUS | 50 | 98,8X26X98,5 | 120 | 2 |
| E-KULT UP 9 | 9 | 3,6 | 91,8 | 94 | 16 | 0,0022 | INFRA-ROUGE | 80/130 | DESSUS | - | 55,8 X 50 X 111,3 | 116 | 2 |
| ELANCE | 8 | 2,4 | 90 | 93 | 22 | 0,02 | INFRA-ROUGE | 80 | ARRIÈRE | 50 | 57,4X54,1X113,1 | 100 | 2 |
| E-WALL EVO 8 C | 7,6 | 3,7 | 90,7 | 92,9 | 18 | 0,011 | RADIO | 80 | DESSUS | 50 | 103 X 28 X 101 | 143 | 2 |
| OLZONE 6 | 6,2 | 2,24 | 94 | 95,69 | 15 | 0,009 | INFRA-ROUGE | 80 | ARRIÈRE | 60 | 58,3 X 52,4 X 119,9 | 120 | 2 |
| SAPHIR 6 | 6 | 2,2 | 93,3 | 94,3 | 19 | 0,003 | INFRA-ROUGE | 80/130 | DESSUS | - | 55,8X51,8X112,3 | 120 | 2 |
| SAPHIR 9 | 9 | 2,2 | 91,8 | 94,3 | 19 | 0,004 | INFRA-ROUGE | 80/130 | DESSUS | - | 55,8X51,8X112,3 | 120 | 2 |
| TBARBARA II 10 | 10 | 3 | 90 | 97,5 | 20 | 0,008 | INFRA-ROUGE | 80 | ARRIÈRE | 50 | 53 X 54 X 109 | 120 | 2 |
| TBARBARA II 12 C | 12 | 3,3 | 88,5 | 95 | 20 | 0,01 | INFRA-ROUGE | 80 | ARRIÈRE | 50 | 53 X 54 X 109 | 125 | 2 |
| TETRA 6 | 6,5 | 2,5 | 92,5 | 94 | 24 | 0,01 | INFRA-ROUGE | 80 | ARRIÈRE | 50 | 48,5 X 48,5 X 109 | 98 | 2 |
| TETRA 8 | 8 | 2,4 | 90 | 93 | 24 | 0,02 | INFRA-ROUGE | 80 | ARRIÈRE | 50 | 48,5 X 48,5 X 109 | 107 | 2 |









INFORMATIONS TECHNIQUES / TECHNICAL INFORMATION

| MODELES | PUISSANCE NOMINALE (kW) | RENDEMENT ÉNERGÉTIQUE MAXI (%) | LONGUEUR DE BÛCHES (cm) | Taux de MONOXYDE DE CARBONE (CO à 13% O2) | RACCORDEMENT POUR L'ÉVACUATION DES FUMÉES (mm) | POSITION DU RACCORDEMENT ÉVACUATION FUMÉE | RACCORDEMENT POUR L'ENTRÉE D'AIR DE COMBUSTION (mm) | DIMENSIONS TOYALES (cm) Largeur x Profondeur x Hauteur | POIDS NET DE L'APPAREIL (kg) | GARANTIE (Année) |
|-------------------------------------|---|---|---|---|---|---|---|--|---|---|
| |  |  |  |  |  |  |  |  |  |  |
| POELES À BOIS FONTE ET ACIER | | | | | | | | | | |
| OSSAU | 10,31 | 77,10 | 50 | 0,11 | 150 | DESSUS | 100 | 104,2 X 44,1 X 96,7 | 255 | 2 |
| ANETO | 7,60 | 75,10 | 15 | 0,08 | 150 | DESSUS | 100 | 58,2 X 42,6 X 119,5 | 155 | 2 |
| MALLET | 6,14 | 81,70 | 12 | 0,07 | 150 | DESSUS | 100 | 48,4 X 48,4 X 120,9 | 130 | 2 |
| LARY | 8 | 80,3 | 50 | 0,04 | 150 | ARRIÈRE OU DESSUS | 100 | 71 X 51 X 115,2 | 147 | 2 |
| ASPIN | 7 | 80,4 | 33 | 0,07 | 150 | DESSUS | 100 | 48X48X114,3 | 106 | 2 |
| ACTUAL ANTHRACITE | 9 | 79 | 33 | 0,09 | 150 | ARRIÈRE OU DESSUS | | 55.6 X 43.3 X 72.3 | 130 | 5 |
| EQUINOXE | 8 | 76 | 33 | 0,09 | 150 | ARRIÈRE OU DESSUS | 100 | 51.5 X 43.0 X 114.0 | 145 | 5 |
| RUSTIQUE ANTHRACITE | 11 | 78 | 50 | 0,09 | 150 | ARRIÈRE OU DESSUS | 100 | 78 X 58.2 X 79 | 210 | 5 |
| SOULOR | 7,4 | 79,3 | 33 | 0,09 | 150 | ARRIÈRE OU DESSUS | 100 | 55,5X55,5X136 | 170 | 2 |
| AUBIS | 7,6 | 80 | 33 | 0,08 | 150 | ARRIÈRE OU DESSUS | 100 | 47,2X47,2X116 | 116 | 2 |
| POELES À BOIS SKANDERBORG | | | | | | | | | | |
| BELLA | 6 | 80 | 47 | 0,08 | 150 | ARRIÈRE OU DESSUS | 100 | 44 X 39 X 132,5 | 170 | 2 |
| CALI | 6 | 80 | 38 | 0,08 | 150 | ARRIÈRE OU DESSUS | 100 | 56,8 X 56 X 125 | 155 | 2 |
| CALI XL | 6 | 80 | 38 | 0,08 | 150 | ARRIÈRE OU DESSUS | 100 | 56,8 X 56 X 150 | 170 | 2 |
| CUBA DA | 5 | 81 | 31 | 0,08 | 150 | ARRIÈRE OU DESSUS | 100 | 60,5 X 44 X 129 | 200 | 2 |
| ACUBIS | 7 | 81 | 25 | 0,07 | | ARRIÈRE OU DESSUS | 100 | 131,5X50,5X174 | 150 | 2 |
| FERRO ELEGANCE | 6 | 80 | 33 | 0,1 | 150 | ARRIÈRE OU DESSUS | 100 | 40 X 40 X 150 | 170 | 2 |
| NIRO II | 6 | 81 | 41 | 0,09 | 150 | ARRIÈRE OU DESSUS | 100 | 46X46X100 | 115 | 2 |
| PILA PIERRE OLLAIRE | 6 | 80 | 35 | 0,04 | 150 | ARRIÈRE OU DESSUS | 100 | 52,5X52,5X151 | 270 | 2 |
| THEA ACIER NOIR | 6 | 79 | 47 | 0,08 | 150 | ARRIÈRE OU DESSUS | 100 | 53 X 39 X 125 | 120 | 2 |
| TIVA | 7 | 81 | 25 | 0,09 | 150 | ARRIÈRE OU DESSUS | 100 | 64,5 X 48 X 92,5 | 150 | 2 |
| TIVA L | 7 | 81 | 25 | 0,09 | 150 | ARRIÈRE OU DESSUS | 100 | 64,5 X 48 X 123,5 | 170 | 2 |
| TIVA XL | 7 | 81 | 25 | 0,09 | 150 | ARRIÈRE OU DESSUS | 100 | 64,5 X 48 X 123,5 | 170 | 2 |
| VERON | 6 | 80 | 35 | 0,04 | 150 | ARRIÈRE OU DESSUS | 100 | 46X46X125,5 | 120 | 2 |
| ZIO | 5 | 80 | 40 | 0,09 | 120 | ARRIÈRE OU DESSUS | 100 | 40 X 34,7 X 109,7 | 110 | 2 |







Les informations mentionnées dans ce catalogues sont données à titre indicatif et peuvent évoluer dans le cadre de l'amélioration continue des produits. Pour toute information, consultez les fiches techniques des produits.

The information in this catalogue is indicative and may change as a result of continuous product improvement. For further information, please consult the technical data sheets of each device.

INFORMATIONS TECHNIQUES / TECHNICAL INFORMATION

| MODELES | PUISSANCE NOMINALE (kW) | RENDEMENT ÉNERGÉTIQUE (%) | LONGUEUR DE BÛCHES (cm) | WOODBOK TECHNOLOGY | TYPE TÉLÉCOMMANDE | TAUX DE MONOXYDE DE CARBONE (CO à 13% O2) | RACCORDEMENT POUR L'ÉVACUATION DES FUMÉES (mm) | POSITION DU RACCORDEMENT ÉVACUATION FUMÉE | RACCORDEMENT POUR L'ENTRÉE D'AIR DE COMBUSTION (mm) | DIMENSIONS TOTALES (cm) Largeur x Profondeur x Hauteur | POIDS NET DE L'APPAREIL (kg) | GARANTIE (Année) |
|-----------------------------|---|---|---|--------------------|---|---|---|--|---|---|---|---|
| |  |  |  | |  |  |  |  |  |  |  |  |
| POELES À BOIS NESTOR MARTIN | | | | | | | | | | | | |
| M43 | 8 | 86 | 40 | ● | RADIO | 0,03 | 180 | DESSUS | - | 69,6 X 37,5 X 89,5 | 197 | 5 |
| TQH13 SOCLE BUCHES | 7 | 85 | 33 | ● | RADIO | 0,02 | 150 | ARRIÈRE OU DESSUS | 150 | 43 X 35.5 X 129.5 | 195 | 5 |
| TQ33 TABLETTE | 6 | 86 | 40 | ● | RADIO | 0,1 | 150 | ARRIÈRE OU DESSUS | 150 | 170 X 51.6 X 83.4 | 260 | 5 |
| TQH33 SOCLE BUCHES | 8 | 81 | 40 | ● | RADIO | 0,08 | 180 | ARRIÈRE OU DESSUS | 180 | 57.6 X 43,4 X 152,3 | 259 | 5 |
| TQH43 SOCLE BUCHES | 8 | 78 | 50 | ● | RADIO | 0,02 | 180 | ARRIÈRE OU DESSUS | 180 | 68 X 48,2 X 123,3 | 284 | 5 |
| STANFORD 9 | 8 | 76 | 40 | - | - | 0,06 | 125 | ARRIÈRE OU DESSUS | 125 | 61X41,9X72,3 | 150 | 5 |
| STANFORD 9+ | 8 | 76 | 40 | - | - | 0,06 | 125 | ARRIÈRE | 125 | 61,6X42,4X78,3 | 170 | 5 |
| STANFORD 12 | 12 | 76 | 50 | - | - | 0,09 | 153 | ARRIÈRE OU DESSUS | 153 | 73,5 X 57 X 79 | 210 | 5 |
| STANFORD 12+ | 12 | 76 | 50 | - | - | 0,09 | 153 | ARRIÈRE | 153 | 74,2 X 52 X 85,7 | 240 | 5 |
| HARMONY I | 8 | 76 | 40 | - | - | 0,06 | 125 | ARRIÈRE OU DESSUS | - | 60,5X36,8X66,5 | 150 | 5 |
| HARMONY III | 12 | 76 | 50 | - | - | 0,09 | 150 | ARRIÈRE | 150 | 73,5X46,8X74,5 | 200 | 5 |
| POELES À GAZ NESTOR MARTIN | | | | | | | | | | | | |
| TQH35 | 10 | 82 | - | - | - | 0 | 100/150 | DESSUS | - | 57.6X43.4X129.3 | 195 | 5 |
| THS15 | 6 | 82 | - | - | - | 0 | 100/150 | DESSUS | - | 43.4X 20 X130 | 87 | 5 |
| TQH15 | 7 | 82 | - | - | - | - | 100/150 | DESSUS | 100 | 43,4 X 36,5 X 125,7 | 139 | 5 |
| S35 | 8.6 | 80 | - | - | - | 0,003 | 100/150 | ARRIÈRE OU DESSUS | 100/150 | 63,2X39,1X75,4 | 115 | 2 |
| S45 | 10.5 | 82 | - | - | - | 0,003 | 100/150 | ARRIÈRE OU DESSUS | 100/150 | 73.5 X 42,6 X 76,6 | 145 | 2 |

INFORMATIONS TECHNIQUES / TECHNICAL INFORMATION

| MODELES | PUISSANCE THERMIQUE MAX (kW) | PUISSANCE THERMIQUE MIN (kW) | RENDMENT ÉNERGÉTIQUE MAX (%) | RENDMENT ÉNERGÉTIQUE MIN (%) | RACCORDEMENT POUR L'ÉVACUATION DES FUMÉES (mm) | DIMENSIONS TOTALES (LXPH) EN CM | DIMENSIONS DE LA VITRE (LXHEP) EN MM | POIDS NET DE L'APPAREIL (kg) | GARANTIE (Année) |
|------------------------|---|---------------------------------|---|---------------------------------|---|--|---|---|---|
| |  | |  | |  |  |  |  |  |
| INSERTS GAZ | | | | | | | | | |
| SWEETLINE 70 | 12 | 11,8 | 84 | 84 | 100/150 | 77.1X33.3X74.3 | 650 X448 X 4 | 61 | 5 |
| SWEETLINE 70 VAD/ VAG | 12 | 11,8 | 84 | 84 | 100/150 | 77.8*33.3*74.3 | 678*448*4 | 61 | 5 |
| SWEETLINE 70 3V | 12 | 11,8 | 84 | 84 | 100/150 | 79.5*33.3*74.3 | 699*448*4 | 60 | 5 |
| SWEETLINE 80 | 12 | 11,8 | 84 | 84 | 100/150 | 87.1*33.3*74.3 | 750*448*4 | 71 | 5 |
| SWEETLINE 80 VAD/ VAG | 12 | 11,8 | 84 | 84 | 100/150 | 87.8*33.3*74.3 | 778*448*4 | 71 | 5 |
| SWEETLINE 80 3V | 12 | 11,8 | 84 | 84 | 100/150 | 89.5*33.3*74.3 | 799*448*4 | 70 | 5 |
| SWEETLINE 100 | 14 | 17 | 84 | 84 | 130/200 | 107.1*33.3*74.3 | 950*448*4 | 76 | 5 |
| SWEETLINE 100 VAD/ VAG | 14 | 17 | 84 | 84 | 130/200 | 107.8*33.3*74.3 | 978*448*4 | 76 | 5 |
| SWEETLINE 100 3V | 14 | 17 | 84 | 84 | 130/200 | 109.5*33.3*74.3 | 999*448*4 | 76 | 5 |
| SWEETLINE 100 EPI | 14 | 17 | 84 | 84 | 130/200 | 113.6*36.3*90.4 | (985+303)*448*4 | 106 | 5 |
| SWEETLINE 100 DF | 14 | 17 | 84 | 84 | 130/200 | 113.6*39.7*90.4 | 961*448*4 | 106 | 5 |
| SWEETLINE 150 | 17,5 | 17 | 84 | 84 | 130/200 | 157.1*33.3*74.3 | 1450*448*4 | 107 | 5 |
| SWEETLINE 150 VAD/ VAG | 17,5 | 17 | 84 | 84 | 130/200 | 157.8*33.3*74.3 | 1478*448*4 | 107 | 5 |
| SWEETLINE 150 3V | 17,5 | 17 | 84 | 84 | 130/200 | 159.5*33.3*74.3 | 1499*448*4 | 107 | 5 |
| SWEETLINE 200 | 22,5 | 21 | 84 | 84 | 130/200 | 213.6*37.4*90.4 | 1961*448*4 | 138 | 5 |
| SWEETLINE 200 EPI | 22,5 | 21 | 84 | 84 | 130/200 | 213.6*36.3*90.4 | (1985+303)*448*4 | 138 | 5 |
| SWEETLINE 200 DF | 22,5 | 21 | 84 | 84 | 130/200 | 213.6*39.7*90.4 | 1961*448*4 | 138 | 5 |

Les informations mentionnées dans ce catalogues sont données à titre indicatif et peuvent évoluer dans le cadre de l'amélioration continue des produits. Pour toute information, consultez les fiches techniques des produits.

The information in this catalogue is indicative and may change as a result of continuous product improvement. For further information, please consult the technical data sheets of each device.



Index cheminées

FIREPLACES INDEX

| | | | | | | | |
|-------------------|---------|-----------------------|---------|----------------------|---------|---------------------|---------|
| A ALINÉA | PAGE 22 | CS48 | PAGE 58 | MERCURIALE | PAGE 21 | VILHONNEUR | PAGE 55 |
| ANTALYA | PAGE 32 | CS50 | PAGE 16 | MOSAÏQUE | PAGE 24 | VILHONNEUR COMPTOIR | PAGE 55 |
| ATLANTA | PAGE 32 | E ECHOISY | PAGE 54 | OLORON | PAGE 38 | VINTAGE | PAGE 22 |
| B BALISIET | PAGE 19 | EPERNAY | PAGE 50 | OPUS | PAGE 27 | VISION | PAGE 36 |
| BALTIMORE | PAGE 27 | F FOREST ANGLE | PAGE 20 | ORSAY | PAGE 40 | Y YOKO | PAGE 23 |
| BASTIDE | PAGE 46 | G GALET | PAGE 39 | PORNICHET | PAGE 38 | Y YOUNG | PAGE 40 |
| BIARRITZ | PAGE 39 | GLAM | PAGE 24 | QUIBERON | PAGE 34 | Z ZEN | PAGE 23 |
| BOAT | PAGE 33 | GRAPHITE | PAGE 35 | R RAMBOUILLET | PAGE 49 | | |
| BRILLAC | PAGE 53 | L LAZORE | PAGE 18 | RAMSES NOIRE | PAGE 36 | | |
| BRISE | PAGE 19 | LINEA | PAGE 35 | RAMSES SABLE | PAGE 37 | | |
| C CALGARY | PAGE 41 | LODGE | PAGE 29 | RIVOLI | PAGE 34 | | |
| CALGARY 530 | PAGE 41 | LOGIS | PAGE 45 | ROCHEFOUCAULT | PAGE 51 | | |
| CHAUVIÈRE | PAGE 47 | LOGIS SANS HOTTE | PAGE 45 | S SEATTLE | PAGE 26 | | |
| CHENEVIÈRE | PAGE 51 | LONGERE | PAGE 47 | SEOUL | PAGE 31 | | |
| CITY | PAGE 28 | LOUISE | PAGE 37 | T TERREFORT | PAGE 50 | | |
| COSMOPOLITE | PAGE 28 | M MALTE | PAGE 29 | TIVOLI | PAGE 18 | | |
| COTTAGE | PAGE 25 | MANOIR | PAGE 46 | TOPAZE | PAGE 25 | | |
| CS41 | PAGE 57 | MARQUISE | PAGE 48 | U ULTIMATE | PAGE 33 | | |
| CS42 | PAGE 59 | MELBOURNE | PAGE 26 | V VENICE | PAGE 30 | | |
| CS43 | PAGE 59 | MENARDIERE | PAGE 44 | | | | |

Index inserts

INSERTS INDEX

| | | | | | |
|----------------------------|---------|--------------------|---------|----------|---------|
| A ATMOS 70 | PAGE 68 | FACEL 500 VERTICAL | PAGE 63 | I VE1000 | PAGE 79 |
| ATMOS 80 | PAGE 68 | FACEL 500 HYDRO | PAGE 92 | | |
| C CLOUD 70R VAD-VAG | PAGE 74 | FACEL 800 EVO | PAGE 64 | | |
| CLOUD 70 3V | PAGE 77 | FACEL 800 VAG/VAD | PAGE 64 | | |
| CLOUD 80R | PAGE 78 | FACEL 800 3V | PAGE 67 | | |
| CLOUD 80 R HYDRO | PAGE 94 | FACEL 1000 EVO | PAGE 67 | | |
| CLOUD 90R VAD-VAG | PAGE 77 | FACEL 1000 HYDRO | PAGE 93 | | |
| CLOUD 90 3V | PAGE 77 | G GAZ | PAGE 98 | | |
| CLOUD 100R | PAGE 78 | H HP700 | PAGE 70 | | |
| CLOUD 100RDF | PAGE 81 | HP800 | PAGE 71 | | |
| CLOUD 100R horizon | PAGE 81 | I IQ 33 | PAGE 90 | | |
| CLOUD 100RDF horizon | PAGE 82 | IQ 43 | PAGE 90 | | |
| CLOUD 120RDF horizon | PAGE 82 | IQH 33 | PAGE 91 | | |
| CLOUD 130R | PAGE 85 | IQH 43 | PAGE 91 | | |
| CLOUD 150R | PAGE 85 | V VN 70 | PAGE 86 | | |
| F FACEL 500 EVO | PAGE 62 | VN 80 | PAGE 87 | | |

Index poêles

STOVES INDEX

| | | | | | |
|-------------------------|----------|------------------------------|----------|----------------------|----------|
| A ACTUAL | PAGE 129 | ICONIC S | PAGE 108 | STANFORD 12 | PAGE 146 |
| ANETO | PAGE 122 | ICONIC C | PAGE 109 | STANFORD 12+ | PAGE 146 |
| ASPIN | PAGE 123 | L LARY | PAGE 126 | T TBARBARA II | PAGE 114 |
| AUBIS | PAGE 124 | M MALLET | PAGE 121 | TETRA | PAGE 116 |
| B BALT | PAGE 117 | M 43 | PAGE 141 | TIVA | PAGE 132 |
| BELLA | PAGE 138 | MQ 33 | PAGE 144 | TIVA L | PAGE 133 |
| C CALI | PAGE 136 | N NIRO DA | PAGE 130 | TIVA XL | PAGE 133 |
| CALI XL | PAGE 136 | O OSSAU | PAGE 120 | THEA | PAGE 139 |
| E-KULT UP | PAGE 111 | P PILA PIERRE OLLAIRE | PAGE 135 | TQHS15 | PAGE 149 |
| E ELANCE II | PAGE 112 | R RUSTIQUE | PAGE 128 | TQ33 | PAGE 142 |
| ELANCE GLASS | PAGE 113 | S S33 | PAGE 145 | TQH13 | PAGE 143 |
| ELANCE FULL GLASS | PAGE 113 | S 43 | PAGE 145 | TQH15 | PAGE 149 |
| EQUINOXE | PAGE 127 | S35 | PAGE 150 | TQH33 | PAGE 143 |
| E-WALL EVO | PAGE 119 | S45 | PAGE 151 | TQH35 | PAGE 148 |
| F FERRO ELEGANCE | PAGE 134 | SAPHIR | PAGE 110 | TQH43 | PAGE 142 |
| H HARMONY I | PAGE 147 | SOULOR | PAGE 125 | V VERON DA | PAGE 131 |
| HARMONY III | PAGE 147 | STANFORD 9 | PAGE 146 | Z ZIO | PAGE 137 |
| I ICONIC O | PAGE 107 | STANFORD 9+ | PAGE 146 | | |

LES SYMBOLES

THE SYMBOLS

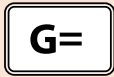

Garantie
Warranty



Crédit d'impôt
Tax credit



Air ventilé
Ventilated air



Puissance : Min-Nominale
POWER: MIN - NOMINAL



Poids
Weight

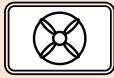

ventilation
Ventilation

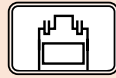

Kit Carénage
Shroud kit



Kit rotation
Rotation Kit



Dimensions totales
Overall dimensions

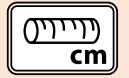

Longueur bûches
LOG LENGTH

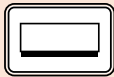

Simple face
One sided

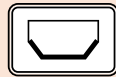

Vitre prismatique
Prismatic door



Vitre galbée
Curved door

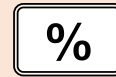

Rendement énergétique
Efficiency

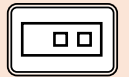

Type télécommande
Remote control type

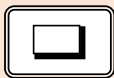

Vitre à droite
Door folded right

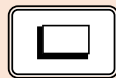

Vitre à gauche
Door folded left

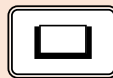

3 vitres
3 glass



Capacité réservoir pellet
Pellet tank capacity



Type de gaz
Type of gas

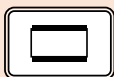

Insert double face
Double-sided door



Vitre 360°
Glass door 360°

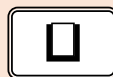

EPI
3 glass EPI

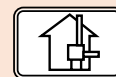

Raccordement air extérieur
Outside air connection

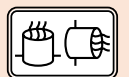

Raccordement dessus
Top Connexion

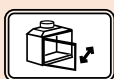

Ouverture latérale
Side opening

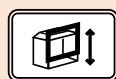

Ouverture relevable
Raising door



Ouverture par basculement
Tottle over opening



Taux de monoxyde de carbone
Rate of carbon monoxide (CO at 13% O2)



Diamètre raccordement sortie fumée
smoke exit Connection diameter

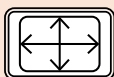

dimension d'encastrement
Embedding dimensions

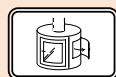

porte latérale
Side door



Restituion calorifique sur circuit EAU
Power transmitted to water

Un système d'étiquette classe les appareils en cinq catégories, (sous la forme d'étoiles). Plus la performance globale de l'appareil est importante, plus le nombre d'étoiles affiché sur l'étiquette est élevé, avec un maximum de 7 étoiles. Pour être labellisés flamme verte, les appareils doivent afficher 7 étoiles. 90% de nos appareils sont labellisés 7 étoiles.



Dans le cadre du label Ecodesign, et en raison de la saturation des laboratoires, certains produits sont encore en cours de tests avant la sortie du catalogue. Pour plus d'informations, et pour consulter la validation des produits, merci de vous rendre sur notre site internet : www.chazelles.com.

Combustible possible*
Possible fuel

* Demandez une étude auprès de votre concessionnaire.
Consult your dealer.

Usage



Chauffage plaisir
Pleasure heating



Chauffage Confort
Confort heating



Chauffage intense
intense heating

La liste des produits ou références, les textes, côtes, images et illustrations, la composition et la couleur des produits, les informations techniques figurant dans ce catalogue n'ont aucune valeur contractuelle. Sous réserve d'erreurs d'impression. Pour plus d'informations contactez votre concessionnaire ou l'usine. Pour améliorer la qualité de ses produits ou pour des raisons techniques, le fabricant peut à tout moment modifier les informations contenues dans ce catalogue.

Les photos présentées dans ce catalogue n'ont aucune valeur contractuelle, dans la mesure où l'impression, la qualité du papier, les éclairages de prises de vues peuvent faire varier les couleurs et textures des différents matériaux de nos produits.

Edition 2021 . Création : CHAZELLES. Photos : Chazelles / Fotolia / Istockphoto / Getty Images.

The list of products or references, texts, ratings, images and illustrations, the composition and colour of products, and the technical information appearing in this catalogue have no contractual value. No liability for printing errors.

For more information contact your dealer or the plant. To improve the quality of his products or for technical reasons, the manufacturer may amend the information in this catalogue at any time. Published 2021. Creation: CHAZELLES.

Photos: Chazelles / Fotolia / Istockphoto / Getty Images.

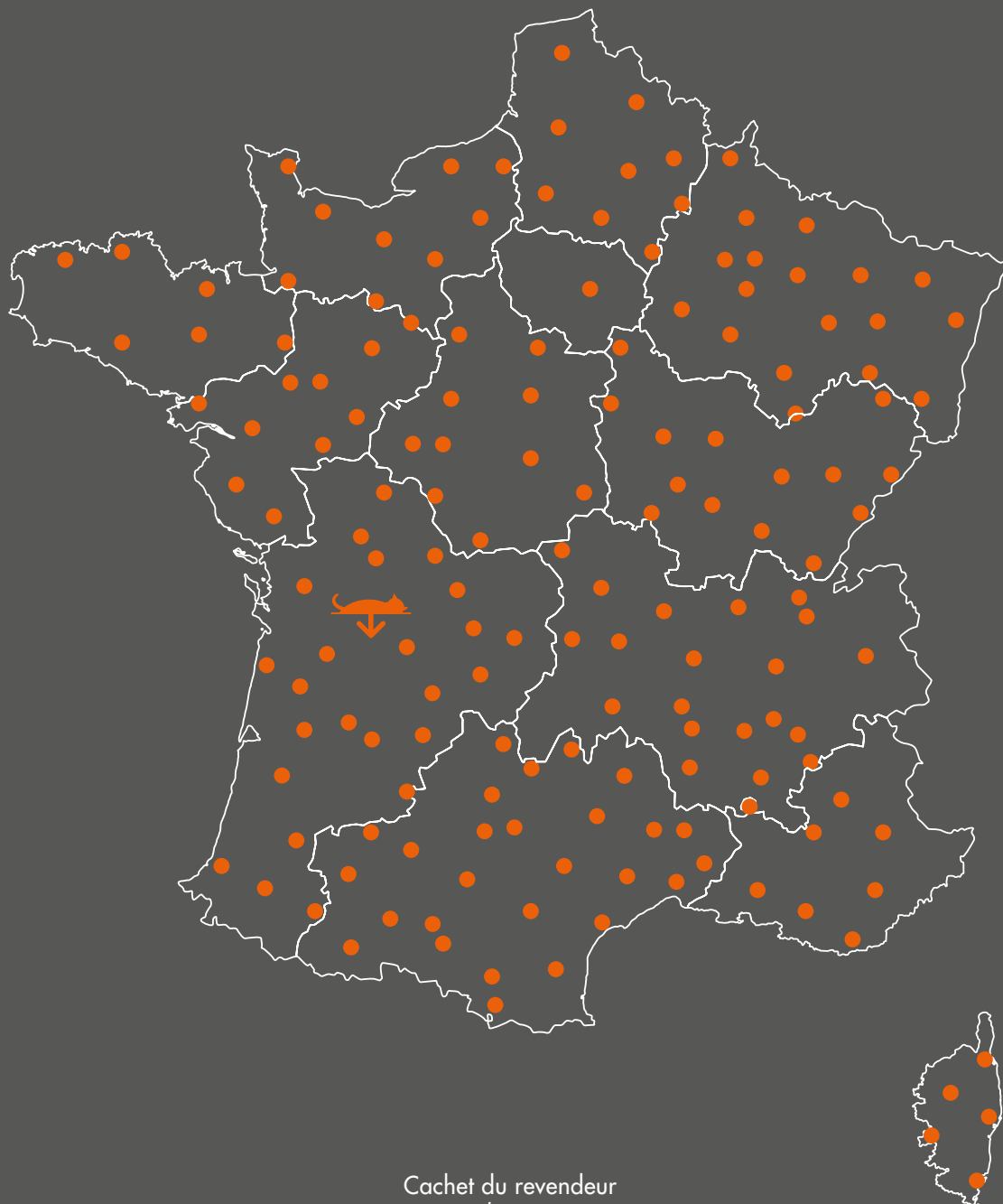

Cachet du revendeur
Dealer stamp

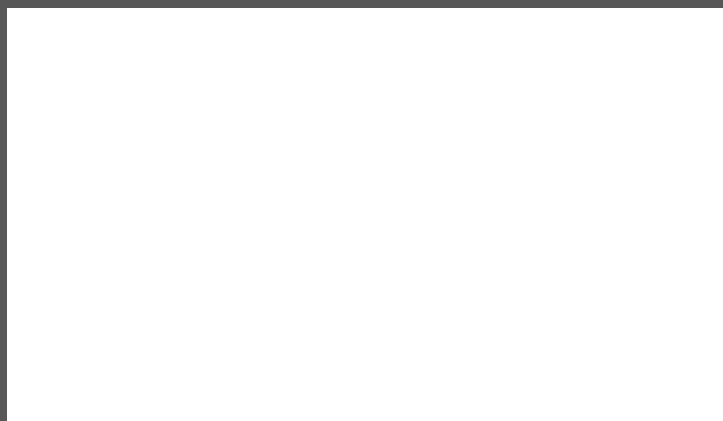

www.chazelles.com